

Tuning-Free AC Servo Motor Unit

## **NX Series**

An AC servo motor unit that is capable of high accuracy control with easy operation. Smooth operation can be achieved in high inertia loads or belt drive applications without manual tuning.



# Tuning-Free AC Servo Motor Unit

## NX Series



### Features

#### ● Easy Operation

As with a stepping motor, stable operation can be achieved in high inertia drive and belt mechanism drive applications without gain adjustment. Also, adjusting the gain manually enables operation under even more stringent load conditions.

#### ◇ Achieves High Inertia Drive

With automatic tuning, operation up to 50 times the rotor inertia is possible. With manual tuning, operation up to 100 times the rotor inertia is possible.

#### ◇ Achieves Smooth Operation with Belt Mechanisms

Belt mechanisms can be operated with the same feel as a stepping motor. Operation without the occurrence of phenomena such as vibration before stopping is possible.

#### ● Conventional Models

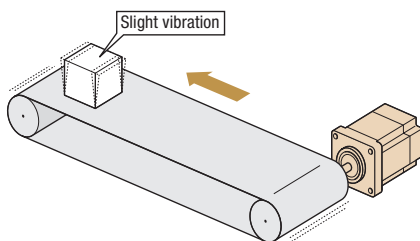

#### ● NX Series

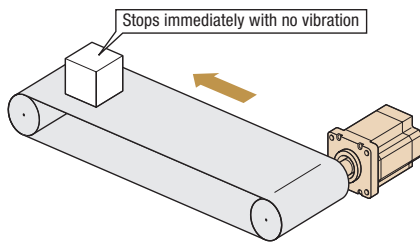

#### ● Easy Handling

Basic settings and adjustments are made with switches and potentiometers on the front panel. This design allows for easy control without a computer and even saves the hassle of complicated UP and DOWN key operations.



#### ● Easy Setting and Easy Monitoring

By using the separately sold control module (**OPX-2A**) or data setting software (**MEXE02**), it is possible to perform changing of parameters, function setting, and monitoring that is better suited to your system.

#### ● Operating Status Waveform Monitoring\*

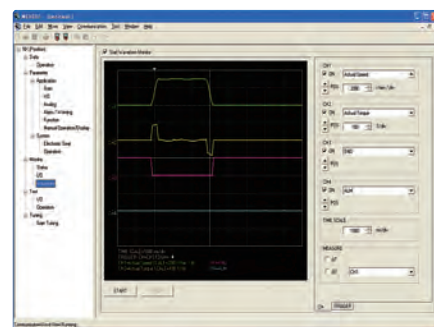

\*Monitoring the operating status waveform requires the data setting software (**MEXE02**), which is sold separately.

#### ● 4 Control Modes

This servo unit can operate in 4 control modes. Also, with the separately sold control module (**OPX-2A**) or data setting software (**MEXE02**), the functions of each control mode can be extended.

Extended functions → Page 32

#### ◇ Position Control

The built-in high-resolution 20-bit absolute encoder enables highly accurate positioning.

#### ● High Speed and High Response

High-speed positioning can be performed utilizing the high-speed and high-response characteristics.

Maximum Speed **5500** r/min

Factory Settling Time **60 to 70** ms

**NX620AA**-◇

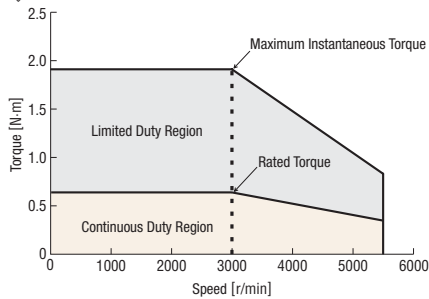

#### ● Damping Control

Eliminates load resonance by adjusting the potentiometer. This adjustment can be made easily and without any bothersome work such as searching for the resonance frequency.

#### <Application Example: Image inspection equipment>

Camera vibration during stopping can be suppressed by using the damping control.

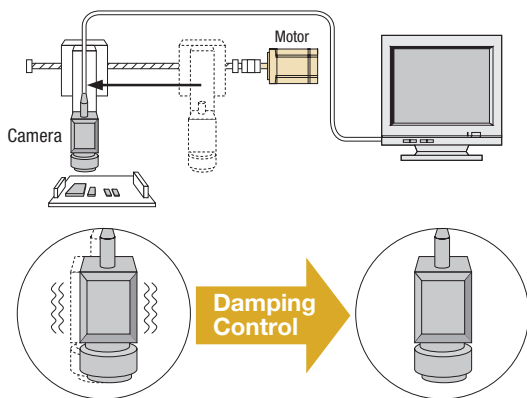

#### ● Absolute System

Use as an absolute system by attaching an optional battery (sold separately) is possible. The current position of the encoder can be stored, so resetting after a blackout or similar occurrence is easy.

#### ◇ Speed Control

The reduction of motor cogging torque and the use of a high-resolution encoder have substantially reduced variation in rotation in the low-speed range (the flutter characteristic), resulting in smooth operation even at low speeds.

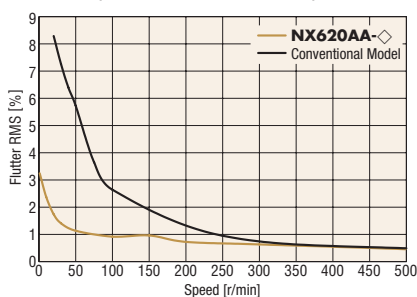

#### ◇ Torque Control

Variation of the generated torque relative to the set torque (torque accuracy) has been improved, resulting in highly accurate torque control.

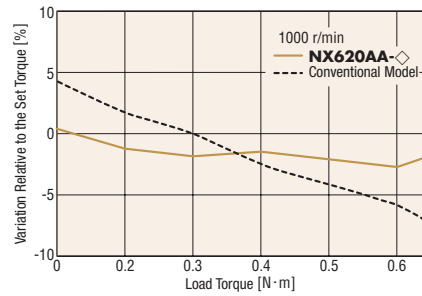

#### ◇ Tension Control

Tension control such as winding films can be easily performed without using a detector or control equipment.

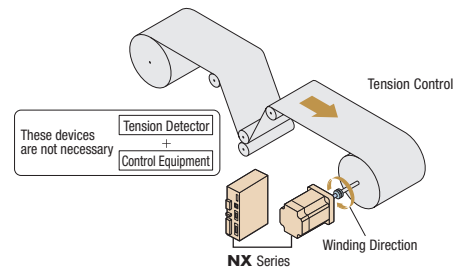

#### ● Degree of Protection IP65

These motors conform to IP65 and they are ideal for use in environments requiring dust resistance and water resistance to protect against cutting dust suspended in air, splashed water droplets, etc.

(Standard type, electromagnetic brake type, **PS** geared type: excluding installation surface and connector locations, **PJ** geared type: excluding connector locations)

#### ● Simple Connections with Included Cables

The **NX** Series comes with cables to connect the motor and driver. You can select from 1 m, 2 m, or 3 m cables. If you need cables longer than 3 m or cables offering superior flexibility, appropriate cables are available as accessories (sold separately).



#### ● Separate Main Power Supply and Control Power Supply

A control power supply terminal that is separate from the main power supply is provided. Even when the main power supply is cut off in the case of, for example, an emergency stop, operations such as position detection and alarm contents checking can be performed if 24 VDC power is supplied to the control power supply terminal. (Operation with only the main power supply is also possible.)

#### ● Conforms to Semiconductor Equipment and Materials International Standards "SEMI F47"

- Conforms to SEMI Standards regarding power supply voltage drop.
- Effective for use in semiconductor equipment. (Always evaluate the product with it mounted on actual equipment.)

● **High Performance Geared Motors**

◇ **High Permissible Torque and Wide Permissible Speed Range**

Geared motors with high permissible torque that fully utilize the motor output torque.

**NX65AA-PS25**-◇

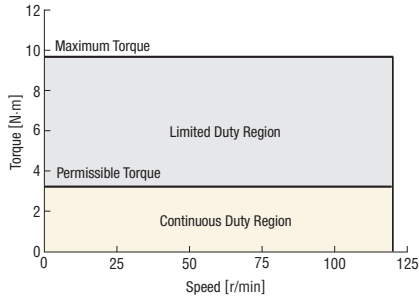

● **PS Geared Type**

**PS** geared motors with a new planetary gear mechanism are available.

◇ **Low Backlash**

The backlash is 15 arc minutes max. These motors can be used in wide-ranging applications.

◇ **Compact and Lightweight Design**

Compared to **PJ** geared types, these are compact, lightweight geared motors.

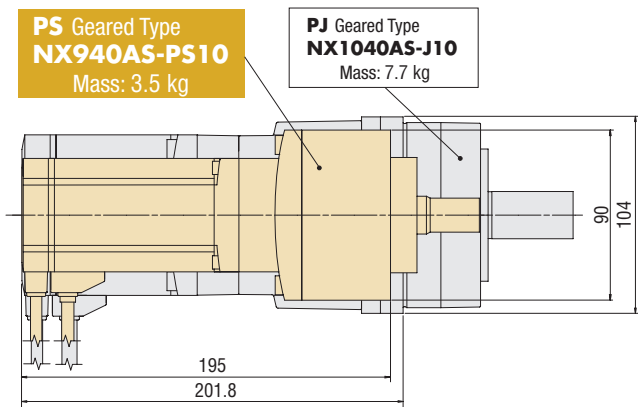

● **PJ Geared Type**

◇ **Non-Backlash**

Geared motors that use high accuracy gears with an angular transmission accuracy of 4 arc minutes and backlash of 3 arc minutes.

◇ **Surface Installation is Possible**

There are screw holes that permit installation of a load directly on the rotating surface integrated with the shaft. Since the load can be installed here directly (surface installation), the design is simple when using an index table.

Screw Hole for Load Installation

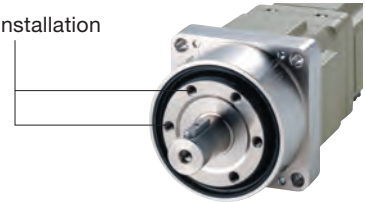

● **Application Example with an Index Table**

Parts that had been necessary, such as pulleys and belts, are no longer necessary.

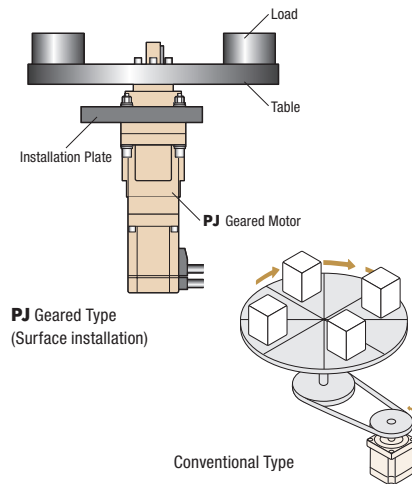

● **Characteristics Comparison for Geared Motor**

The motor and driver package comes in 4 geared motor frame sizes ranging from 60 to 104 mm.

(□60: indicates a frame size of 60 mm.)

	Geared Type	Features	Power Supply Input	Output Power				
				50 W	100 W	200 W	400 W	750 W
Low Backlash	<b>PS</b> Geared Type (Planetary gear mechanism) 	<ul style="list-style-type: none"> <li>High Speed (Low gear ratio)</li> <li>High Permissible Torque/Maximum Torque</li> <li>Center Shaft</li> <li>Gear Ratio Types 1:5, 1:10, 1:25</li> </ul>	Single-Phase 100-115 VAC	□60	□60	□90		
			Single-Phase/Three-Phase 200-230 VAC	□60	□60	□90		
			Three-Phase 200-230 VAC				□90	
Non-Backlash	<b>PJ</b> Geared Type (Planetary gear mechanism) 	<ul style="list-style-type: none"> <li>High Speed (Low gear ratio)</li> <li>High Positioning Accuracy</li> <li>High Permissible Torque/Maximum Torque</li> <li>Center Shaft</li> <li>Surface installation is possible</li> <li>Gear Ratio Types 1:5, 1:10, 1:25</li> </ul>	Single-Phase 100-115 VAC		□80	□80		
			Single-Phase/Three-Phase 200-230 VAC		□80	□80		
			Three-Phase 200-230 VAC				□104	□104



## System Configuration

### Standard Type with Electromagnetic Brake

An example of a single axis system configuration with the **SG8030J** controller in position control mode is shown below.

\*Not supplied

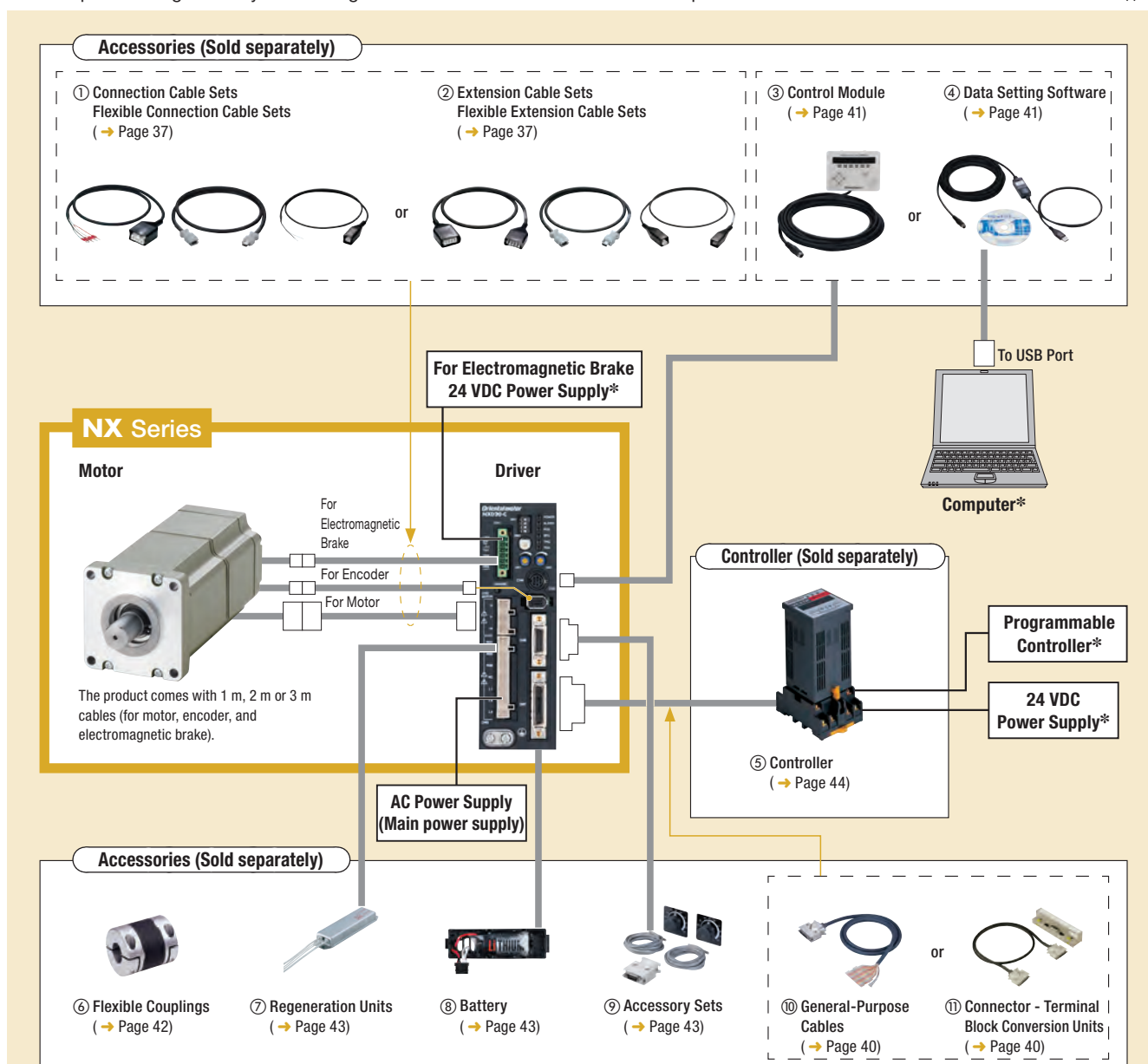

Number	Name	Overview	Reference Page
①	Connection Cable Sets Flexible Connection Cable Sets	These cable sets are used to connect the motor and driver without using the included cables. (Cables are from 1 to 20 m.)	37
②	Extension Cable Sets Flexible Extension Cable Sets	These cable sets are used to extend the wiring distance between the motor and driver using the included cables. (Cables are from 1 to 15 m.)	37
③	Control Module	Various data can be set (edited, monitored and operated) and functions can be extended. The communication cable length is 5 m.	41
④	Data Setting Software	Using a computer, various data can be set (edited, monitored and operated) and functions can be extended. A PC Interface Cable (5 m) and USB cable (0.5 m) are included.	41
⑤	Controller	This controller outputs pulse commands that determine the rotation amount and speed of the servo motor.	44
⑥	Flexible Couplings	Couplings that connect the motor shaft to the driven shaft.	42
⑦	Regeneration Units	When the regenerative power generated by the motor exceeds the driver's regenerative power absorption capacity, connect a unit to the driver to release the regenerative power.	43
⑧	Battery	Battery for constructing an absolute system. Position information can be stored by installing this battery on the driver during power blackouts or if the driver's power supply is switched OFF.	43
⑨	Accessory Sets	The connector and external speed potentiometer used when analog I/O is used come as a set. The connector is also available by itself.	43
⑩	General-Purpose Cables	General-purpose cables for connecting the driver and controller (1 m, 2 m).	40
⑪	Connector - Terminal Block Conversion Units	Set of terminal block and cable for connecting the driver and controller (1 m).	40

### System Configuration Price Example

NX Series	+	Sold Separately						
		Controller	Flexible Coupling	Regeneration Unit	Battery	Accessory Set	Connector - Terminal Block Conversion Unit (1 m)	Data Setting Software
<b>NX620MC-3</b>		<b>SG8030J-D</b>	<b>MCV300814</b>	<b>RGB100</b>	<b>BAT01A</b>	<b>AS-SV2</b>	<b>CC36T1</b>	<b>MEXE02</b>

The system configuration shown above is an example. Other combinations are available.

## Product Number Code

# NX 8 20 M A - J 25 - 1

① ② ③ ④ ⑤ ⑥ ⑦ ⑧

①	Series Name	<b>NX: NX</b> Series
②	Motor Frame Size	<b>4:</b> 42 mm <b>6:</b> 60 mm (60 mm) <b>8:</b> (80 mm) <b>9:</b> 85 mm (90 mm) <b>10:</b> (104 mm) ( ) indicates the frame size for the gearhead
③	Output Power	<b>5:</b> 50 W <b>10:</b> 100 W <b>20:</b> 200 W <b>40:</b> 400 W <b>75:</b> 750 W
④	Configuration	<b>A:</b> Standard <b>M:</b> Electromagnetic Brake Type
⑤	Power-Supply Input	<b>A:</b> Single-Phase 100–115 VAC <b>C:</b> Single-Phase/Three-Phase 200–230 VAC <b>S:</b> Three-Phase 200–230 VAC
⑥	Gear Type	<b>PS: PS</b> Geared Type <b>J: PJ</b> Geared Type Blank: Standard Type
⑦	Gear Ratio	
⑧	Cable Length (Included)	<b>1:</b> 1 m <b>2:</b> 2 m <b>3:</b> 3 m

## Product Line

### Standard Type

Power-Supply Input	Output Power	Product Name
Single-Phase 100-115 VAC	50 W	<b>NX45AA-◇</b>
	100 W	<b>NX410AA-◇</b>
	200 W	<b>NX620AA-◇</b>
Single-Phase/Three-Phase 200-230 VAC	50 W	<b>NX45AC-◇</b>
	100 W	<b>NX410AC-◇</b>
	200 W	<b>NX620AC-◇</b>
Three-Phase 200-230 VAC	400 W	<b>NX640AS-◇</b>
	750 W	<b>NX975AS-◇</b>

### PS Geared Type

Power-Supply Input	Output Power	Product Name
Single-Phase 100-115 VAC	50 W	<b>NX65AA-PS5-◇</b>
		<b>NX65AA-PS10-◇</b>
		<b>NX65AA-PS25-◇</b>
	100 W	<b>NX610AA-PS5-◇</b>
		<b>NX610AA-PS10-◇</b>
		<b>NX610AA-PS25-◇</b>
Single-Phase/Three-Phase 200-230 VAC	50 W	<b>NX65AC-PS5-◇</b>
		<b>NX65AC-PS10-◇</b>
		<b>NX65AC-PS25-◇</b>
	100 W	<b>NX610AC-PS5-◇</b>
		<b>NX610AC-PS10-◇</b>
		<b>NX610AC-PS25-◇</b>
200 W	<b>NX920AC-PS5-◇</b>	
	<b>NX920AC-PS10-◇</b>	
	<b>NX920AC-PS25-◇</b>	
Three-Phase 200-230 VAC	400 W	<b>NX940AS-PS5-◇</b>
		<b>NX940AS-PS10-◇</b>
		<b>NX940AS-PS25-◇</b>

### PJ Geared Type

Power-Supply Input	Output Power	Product Name
Single-Phase 100-115 VAC	100 W	<b>NX810AA-J5-◇</b>
		<b>NX810AA-J10-◇</b>
		<b>NX810AA-J25-◇</b>
	200 W	<b>NX820AA-J5-◇</b>
		<b>NX820AA-J10-◇</b>
		<b>NX820AA-J25-◇</b>
Single-Phase/Three-Phase 200-230 VAC	100 W	<b>NX810AC-J5-◇</b>
		<b>NX810AC-J10-◇</b>
		<b>NX810AC-J25-◇</b>
	200 W	<b>NX820AC-J5-◇</b>
		<b>NX820AC-J10-◇</b>
		<b>NX820AC-J25-◇</b>
Three-Phase 200-230 VAC	400 W	<b>NX1040AS-J5-◇</b>
		<b>NX1040AS-J10-◇</b>
		<b>NX1040AS-J25-◇</b>
	750 W	<b>NX1075AS-J5-◇</b>
		<b>NX1075AS-J10-◇</b>
		<b>NX1075AS-J25-◇</b>

### Standard Type with Electromagnetic Brake

Power-Supply Input	Output Power	Product Name
Single-Phase 100-115 VAC	50 W	<b>NX45MA-◇</b>
	100 W	<b>NX410MA-◇</b>
	200 W	<b>NX620MA-◇</b>
Single-Phase/Three-Phase 200-230 VAC	50 W	<b>NX45MC-◇</b>
	100 W	<b>NX410MC-◇</b>
	200 W	<b>NX620MC-◇</b>
Three-Phase 200-230 VAC	400 W	<b>NX640MS-◇</b>
	750 W	<b>NX975MS-◇</b>

### PS Geared Type with Electromagnetic Brake

Power-Supply Input	Output Power	Product Name
Single-Phase 100-115 VAC	50 W	<b>NX65MA-PS5-◇</b>
		<b>NX65MA-PS10-◇</b>
		<b>NX65MA-PS25-◇</b>
	100 W	<b>NX610MA-PS5-◇</b>
		<b>NX610MA-PS10-◇</b>
		<b>NX610MA-PS25-◇</b>
Single-Phase/Three-Phase 200-230 VAC	50 W	<b>NX65MC-PS5-◇</b>
		<b>NX65MC-PS10-◇</b>
		<b>NX65MC-PS25-◇</b>
	100 W	<b>NX610MC-PS5-◇</b>
		<b>NX610MC-PS10-◇</b>
		<b>NX610MC-PS25-◇</b>
200 W	<b>NX920MC-PS5-◇</b>	
	<b>NX920MC-PS10-◇</b>	
	<b>NX920MC-PS25-◇</b>	
Three-Phase 200-230 VAC	400 W	<b>NX940MS-PS5-◇</b>
		<b>NX940MS-PS10-◇</b>
		<b>NX940MS-PS25-◇</b>

### PJ Geared Type with Electromagnetic Brake

Power-Supply Input	Output Power	Product Name
Single-Phase 100-115 VAC	100 W	<b>NX810MA-J5-◇</b>
		<b>NX810MA-J10-◇</b>
		<b>NX810MA-J25-◇</b>
	200 W	<b>NX820MA-J5-◇</b>
		<b>NX820MA-J10-◇</b>
		<b>NX820MA-J25-◇</b>
Single-Phase/Three-Phase 200-230 VAC	100 W	<b>NX810MC-J5-◇</b>
		<b>NX810MC-J10-◇</b>
		<b>NX810MC-J25-◇</b>
	200 W	<b>NX820MC-J5-◇</b>
		<b>NX820MC-J10-◇</b>
		<b>NX820MC-J25-◇</b>
Three-Phase 200-230 VAC	400 W	<b>NX1040MS-J5-◇</b>
		<b>NX1040MS-J10-◇</b>
		<b>NX1040MS-J25-◇</b>
	750 W	<b>NX1075MS-J5-◇</b>
		<b>NX1075MS-J10-◇</b>
		<b>NX1075MS-J25-◇</b>

● A number indicating the desired length of **1** (1 m), **2** (2 m) or **3** (3 m) for the cables included with the product is entered where the box ◇ is located within the product name. Select a desired cable length from 1 m, 2 m and 3 m.

● If you need cables longer than 3 m or cables offering excellent flexibility, select appropriate cables from the accessories (sold separately). Refer to page 37 for details.

The following items are included in each product.

Motor, Driver, Cable for Motor\*, Cable for Encoder\*, Cable for Electromagnetic Brake\* (Electromagnetic brake type only), Connector for I/O Signal, Motor Connector, Connector for Regeneration Unit Input/Main Power Input Terminals, Connector for 24 VDC Power-Supply Input/Regeneration Unit Thermal Input/Electromagnetic Brake Terminals, Connector Wiring Lever, Operating Manual

\*The product comes with 1 m, 2 m, or 3 m cables including a cable for motor, cable for encoder, and cable for electromagnetic brake (electromagnetic brake type only). If you need cables longer than 3 m or cables offering excellent flexibility, select appropriate cables from the accessories (sold separately). Refer to page 37 for details.

# Standard Type Frame Size 42 mm, 60 mm, 85 mm

## Specifications (RoHS)



Product Name		Standard	<b>NX45A</b> □-◇	<b>NX410A</b> □-◇	<b>NX620A</b> □-◇	<b>NX640AS</b> -◇	<b>NX975AS</b> -◇
Electromagnetic Brake Type			<b>NX45M</b> □-◇	<b>NX410M</b> □-◇	<b>NX620M</b> □-◇	<b>NX640MS</b> -◇	<b>NX975MS</b> -◇
Rated Output Power	W		50	100	200	400	750
Rated Speed	r/min				3000		
Maximum Speed	r/min				5500		
Rated Torque	N·m		0.159	0.318	0.637	1.27	2.39
Maximum Instantaneous Torque	N·m		0.478	0.955	1.91	3.82	7.16
Rotor Inertia	J: kg·m <sup>2</sup>		0.0174×10 <sup>-4</sup> [0.0217×10 <sup>-4</sup> ]*1	0.0290×10 <sup>-4</sup> [0.0334×10 <sup>-4</sup> ]*1	0.162×10 <sup>-4</sup> [0.185×10 <sup>-4</sup> ]*1	0.291×10 <sup>-4</sup> [0.314×10 <sup>-4</sup> ]*1	0.948×10 <sup>-4</sup> [1.03×10 <sup>-4</sup> ]*1
Permissible Load Inertia*2	J: kg·m <sup>2</sup>		1.74×10 <sup>-4</sup>	2.90×10 <sup>-4</sup>	16.2×10 <sup>-4</sup>	29.1×10 <sup>-4</sup>	94.8×10 <sup>-4</sup>
Resolution	P/R		100 to 100000 (Factory setting 1000)				
Detector			Absolute Encoder 1 rotation 20 bits, multiple rotations 16 bits				
Power-Supply Input	Voltage and Frequency	AC Main Power Supply	Single-Phase 100-115 VAC -15% to +10% 50/60 Hz Single-Phase 200-230 VAC -15% to +10% 50/60 Hz Three-Phase 200-230 VAC -15% to +10% 50/60 Hz			Three-Phase 200-230 VAC -15% to +10% 50/60 Hz	
		DC Control Power Supply	24 VDC±10% 0.8 A				
Rated Input Current*3	A	Single-Phase 100-115 VAC	1.9	2.9	4.6		—
		Single-Phase 200-230 VAC	1.2	1.8	2.8		—
		Three-Phase 200-230 VAC	0.7	1	1.6	2.8	4.7
Electromagnetic Brake*4	Type		Power Off Activated Type				
	Power-Supply Input		24 VDC±10%				
	Power Consumption	W	6.1		7.2		8.5
	Excitation Current	A	0.25		0.3		0.35
	Static Friction Torque	N·m	0.159	0.318	0.637	1.27	2.39

\*1 The brackets [ ] indicate the specifications for the electromagnetic brake type.

\*2 With automatic tuning, operation up to 50 times the rotor inertia is possible; with manual tuning, operation up to 100 times the rotor inertia is possible.

\*3 These values are for operation in the continuous duty region. For operation in the limited duty region, the maximum current is approximately 3 times the value shown.

\*4 The electromagnetic brake is for holding the position when the power supply is OFF. The electromagnetic brake cannot be used to stop the motor. A separate power supply for the electromagnetic brake is also required.

### Note

● For continuous operation of the motor at the rated values, a heat sink with aluminum plate size dimensions that are equal to or higher than those shown below is required.

**NX45**□-◇, **NX410**□-◇, **NX620**□-◇: 250×250 mm Thickness 6 mm

**NX640**□S-◇: 300×300 mm Thickness 10 mm

**NX975**□S-◇: 350×350 mm Thickness 10 mm

## Speed – Torque Characteristics

**NX45**□-◇

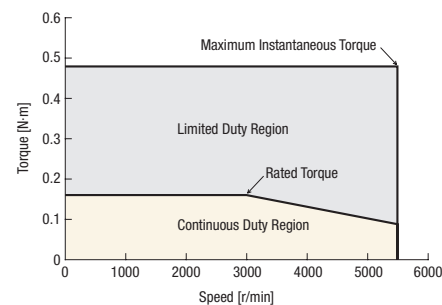

**NX410**□-◇

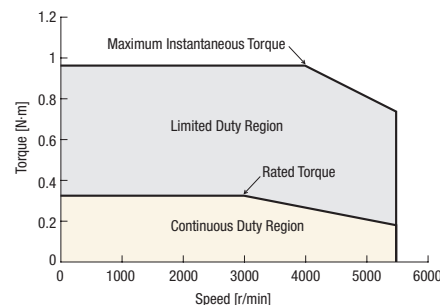

**NX620**□-◇

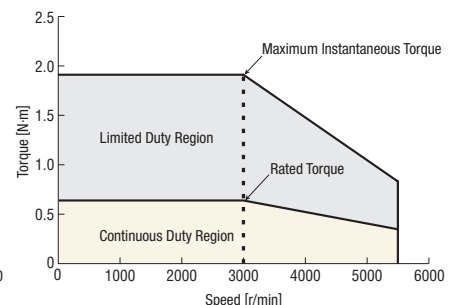

**NX640**□S-◇

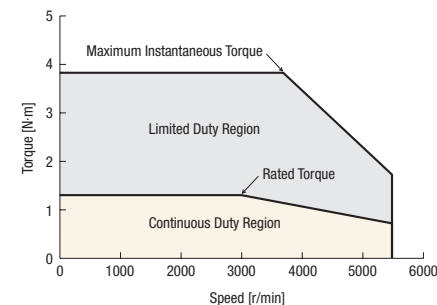

**NX975**□S-◇

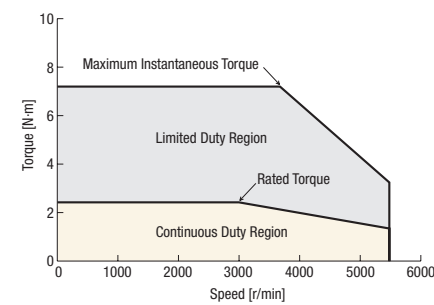

● Either **A** (standard) or **M** (electromagnetic brake type) indicating the motor shaft configuration is entered where the box □ is located within the product name.

Either **A** (single-phase 100-115 VAC) or **C** (single-phase 200-230 VAC/three-phase 200-230 VAC) indicating the power supply voltage is entered where the box □ is located within the product name.

A number indicating the desired length of **1** (1 m), **2** (2 m) or **3** (3 m) for the cables included with the product is entered where the box ◇ is located within the product name.

● Depending on the operating conditions, a regeneration unit may be required. Regeneration Unit → Page 43

# PS Geared Type Frame Size 60 mm

## Specifications RoHS



Product Name	Standard Electromagnetic Brake Type	NX65A□-PS5-◇	NX65A□-PS10-◇	NX65A□-PS25-◇	NX610A□-PS5-◇	NX610A□-PS10-◇	NX610A□-PS25-◇
		NX65M□-PS5-◇	NX65M□-PS10-◇	NX65M□-PS25-◇	NX610M□-PS5-◇	NX610M□-PS10-◇	NX610M□-PS25-◇
Rated Output Power	W	50			100		
Motor Permissible Speed	r/min	3000					
Permissible Torque	N·m	0.716	1.43	3.22	1.43	2.86	6.44
Maximum Torque	N·m	2.15	4.29	9.66	4.29	8.59	19.3
Permissible Speed Range	r/min	0~600	0~300	0~120	0~600	0~300	0~120
Rotor Inertia	J: kg·m <sup>2</sup>	0.0174×10 <sup>-4</sup> [0.0217×10 <sup>-4</sup> ]*1			0.0290×10 <sup>-4</sup> [0.0334×10 <sup>-4</sup> ]*1		
Gearhead Internal Inertia*2	J: kg·m <sup>2</sup>	0.0431×10 <sup>-4</sup>	0.0433×10 <sup>-4</sup>	0.0436×10 <sup>-4</sup>	0.0431×10 <sup>-4</sup>	0.0433×10 <sup>-4</sup>	0.0436×10 <sup>-4</sup>
Permissible Load Inertia*3	J: kg·m <sup>2</sup>	0.0022	0.0087	0.054	0.0036	0.0145	0.091
Gear Ratio		5	10	25	5	10	25
Resolution*4	P/R	100 to 100000 (Factory setting 1000)					
Detector		Absolute Encoder 1 rotation 20 bits, multiple rotations 16 bits					
Backlash	arc minutes (degrees)	15					
Power-Supply Input	Voltage and Frequency	AC Main Power Supply		Single-Phase 100-115 VAC -15 to +10% 50/60 Hz Single-Phase 200-230 VAC -15 to +10% 50/60 Hz Three-Phase 200-230 VAC -15 to +10% 50/60 Hz			
		DC Control Power Supply		24 VDC±10% 0.8 A			
	Rated Input Current*5 A	Single-Phase 100-115 VAC		1.9		2.9	
		Single-Phase 200-230 VAC		1.2		1.8	
Three-Phase 200-230 VAC		0.7		1.0			
Electromagnetic Brake*6	Type	Power Off Activated Type					
	Power-Supply Input	24 VDC±10%					
	Power Consumption W	6.1					
	Excitation Current A	0.25					
	Static Friction Torque N·m	0.716	1.43	3.22	1.43	2.86	6.44

\*1 The brackets [ ] indicate the value for the electromagnetic brake type.

\*2 The gearhead internal inertia is the motor shaft converted value.

\*3 The value for 50 times the rotor inertia.

\*4 The resolution for the motor output shaft.

\*5 These values are for operation in the continuous duty region. For operation in the limited duty region, the maximum current is approximately 3 times the value shown.

\*6 The electromagnetic brake is for holding the position when the power supply is OFF. The electromagnetic brake cannot be used to stop the motor. A separate power supply for the electromagnetic brake is also required.

## Speed – Torque Characteristics

NX65□-PS5-◇

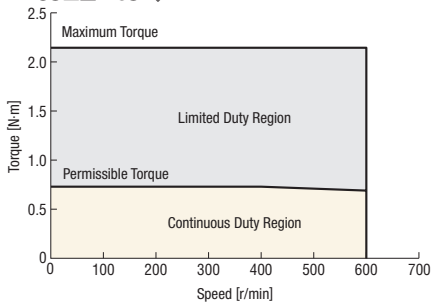

NX65□-PS10-◇

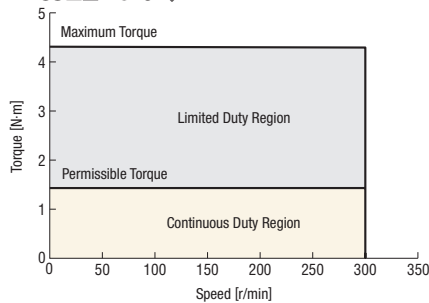

NX65□-PS25-◇

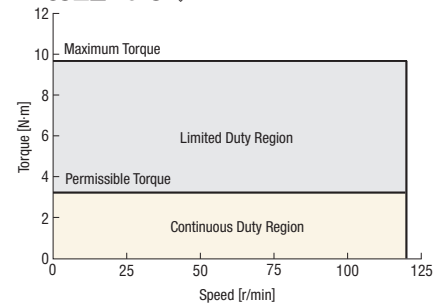

NX610□-PS5-◇

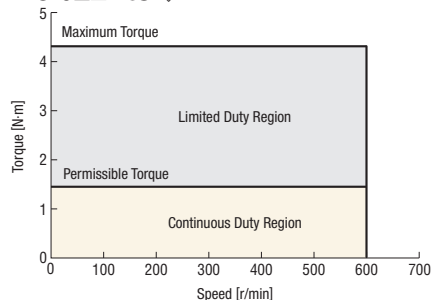

NX610□-PS10-◇

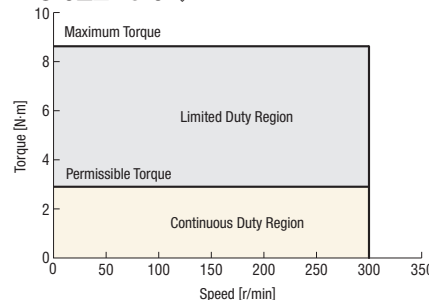

NX610□-PS25-◇

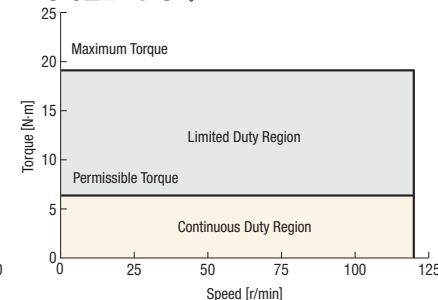

● Either **A** (standard) or **M** (electromagnetic brake type) indicating the motor shaft configuration is entered where the box □ is located within the product name.

Either **A** (single-phase 100-115 VAC) or **C** (single-phase 200-230 VAC/three-phase 200-230 VAC) indicating the power supply voltage is entered where the box □ is located within the product name. A number indicating the desired length of **1** (1 m), **2** (2 m) or **3** (3 m) for the cables included with the product is entered where the box ◇ is located within the product name.

● Depending on the operating conditions, a regeneration unit may be required. Regeneration Unit → Page 43



# PS Geared Type Frame Size 90 mm

## Specifications RoHS



Product Name	Standard	NX920A□-PS5-◇	NX920A□-PS10-◇	NX920A□-PS25-◇	NX940AS-PS5-◇	NX940AS-PS10-◇	NX940AS-PS25-◇
	Electromagnetic Brake Type	NX920M□-PS5-◇	NX920M□-PS10-◇	NX920M□-PS25-◇	NX940MS-PS5-◇	NX940MS-PS10-◇	NX940MS-PS25-◇
Rated Output Power	W	200			400		
Motor Permissible Speed	r/min	3000					
Permissible Torque	N·m	2.87	5.73	12.9	5.72	11.4	25.7
Maximum Torque	N·m	8.6	17.2	38.7	17.1	34.3	77.2
Permissible Speed Range	r/min	0~600	0~300	0~120	0~600	0~300	0~120
Rotor Inertia	J: kg·m <sup>2</sup>	0.162×10 <sup>-4</sup> [0.185×10 <sup>-4</sup> ]*1			0.291×10 <sup>-4</sup> [0.314×10 <sup>-4</sup> ]*1		
Gearhead Internal Inertia*2	J: kg·m <sup>2</sup>	0.163×10 <sup>-4</sup>	0.160×10 <sup>-4</sup>	0.175×10 <sup>-4</sup>	0.163×10 <sup>-4</sup>	0.160×10 <sup>-4</sup>	0.175×10 <sup>-4</sup>
Permissible Load Inertia*3	J: kg·m <sup>2</sup>	0.02	0.081	0.51	0.036	0.146	0.91
Gear Ratio		5	10	25	5	10	25
Resolution*4	P/R	100 to 100000 (Factory setting 1000)					
Detector		Absolute Encoder 1 rotation 20 bits, multiple rotations 16 bits					
Backlash	arc minutes (degrees)	15					
Power-Supply Input	Voltage and Frequency	AC Main Power Supply	Single-Phase 100-115 VAC -15 to +10% 50/60 Hz Single-Phase 200-230 VAC -15 to +10% 50/60 Hz Three-Phase 200-230 VAC -15 to +10% 50/60 Hz			Three-Phase 200-230 VAC -15% to +10% 50/60 Hz	
		DC Control Power Supply	24 VDC±10% 0.8 A				
	Rated Input Current*5 A	Single-Phase 100-115 VAC	4.6			-	
		Single-Phase 200-230 VAC Three-Phase 200-230 VAC	2.8 1.6			- 2.8	
Electromagnetic Brake*6	Type	Power Off Activated Type					
	Power-Supply Input	24 VDC±10%					
	Power Consumption W	7.2					
	Excitation Current A	0.3					
	Static Friction Torque N·m	2.87	5.73	12.9	5.72	11.4	25.7

\*1 The brackets [ ] indicate the specifications for the electromagnetic brake type.

\*2 The gearhead internal inertia is the motor shaft converted value.

\*3 The value for 50 times the rotor inertia.

\*4 The resolution for the motor output shaft.

\*5 These values are for operation in the continuous duty region. For operation in the limited duty region, the maximum current is approximately 3 times the value shown.

\*6 The electromagnetic brake is for holding the position when the power supply is OFF. The electromagnetic brake cannot be used to stop the motor. A separate power supply for the electromagnetic brake is also required.

\*7 NX920 only

## Speed – Torque Characteristics

NX920□-PS5-◇

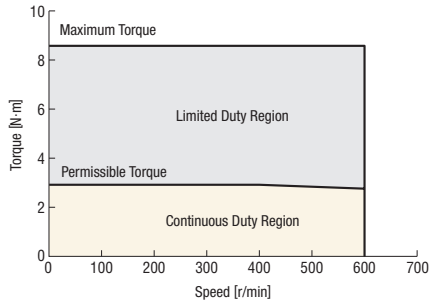

NX920□-PS10-◇

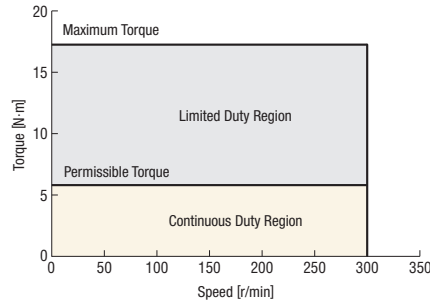

NX920□-PS25-◇

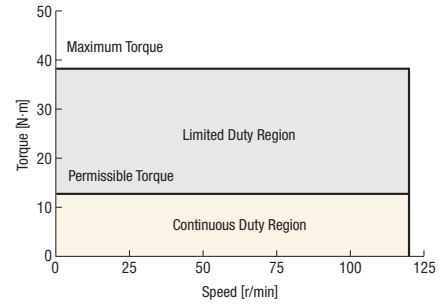

NX940□S-PS5-◇

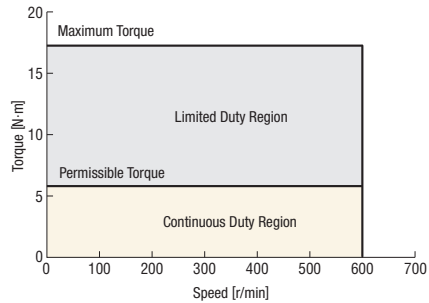

NX940□S-PS10-◇

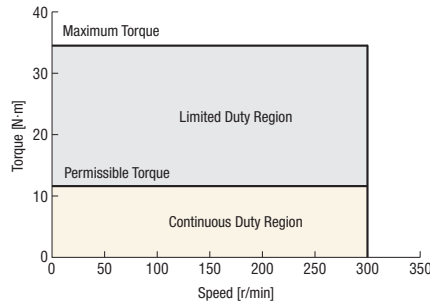

NX940□S-PS25-◇

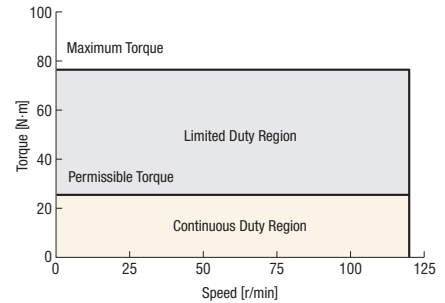

● Either **A** (standard) or **M** (electromagnetic brake type) indicating the motor shaft configuration is entered where the box □ is located within the product name.

● Either **A** (single-phase 100-115 VAC) or **C** (single-phase 200-230 VAC/three-phase 200-230 VAC) indicating the power supply voltage is entered where the box □ is located within the product name. A number indicating the desired length of **1** (1 m), **2** (2 m) or **3** (3 m) for the cables included with the product is entered where the box ◇ is located within the product name.

● Depending on the operating conditions, a regeneration unit may be required. Regeneration Unit → Page 43

# PJ Geared Type Frame Size 80 mm

## Specifications RoHS



Product Name	Standard	NX810A□-J5-◇	NX810A□-J10-◇	NX810A□-J25-◇	NX820A□-J5-◇	NX820A□-J10-◇	NX820A□-J25-◇
	Electromagnetic Brake Type	NX810M□-J5-◇	NX810M□-J10-◇	NX810M□-J25-◇	NX820M□-J5-◇	NX820M□-J10-◇	NX820M□-J25-◇
Rated Output Power	W	100			200		
Motor Permissible Speed	r/min	3000					
Permissible Torque	N·m	1.27	2.54	6.36	2.54	5.1	12.7
Maximum Torque	N·m	3.82	7.63	19.1	7.63	15.3	38.2
Permissible Speed Range	r/min	0~600	0~300	0~120	0~600	0~300	0~120
Rotor Inertia	J: kg·m <sup>2</sup>	0.095×10 <sup>-4</sup> [0.118×10 <sup>-4</sup> ]*1			0.160×10 <sup>-4</sup> [0.182×10 <sup>-4</sup> ]*1		
Gearhead Internal Inertia*2	J: kg·m <sup>2</sup>	0.481×10 <sup>-4</sup>	0.363×10 <sup>-4</sup>	0.351×10 <sup>-4</sup>	0.481×10 <sup>-4</sup>	0.363×10 <sup>-4</sup>	0.351×10 <sup>-4</sup>
Permissible Load Inertia*3	J: kg·m <sup>2</sup>	0.012	0.0475	0.297	0.02	0.08	0.5
Gear Ratio		5	10	25	5	10	25
Resolution*4	P/R	100 to 100000 (Factory setting 1000)					
Detector		Absolute Encoder 1 rotation 20 bits, multiple rotations 16 bits					
Backlash	arc minutes (degrees)	3					
Power-Supply Input	Voltage and Frequency	AC Main Power Supply	Single-Phase 100~115 VAC -15 to +10% 50/60 Hz				
			Single-Phase 200~230 VAC -15 to +10% 50/60 Hz				
	DC Control Power Supply	24 VDC±10% 0.8 A					
	Rated Input Current*5 A	Single-Phase 100-115 VAC	2.8			4.6	
Single-Phase 200-230 VAC		1.8			2.8		
Three-Phase 200-230 VAC		1			1.6		
Electromagnetic Brake*6	Type	Power Off Activated Type					
	Power-Supply Input	24 VDC±10%					
	Power Consumption W	7.2					
	Excitation Current A	0.3					
	Static Friction Torque N·m	1.27	2.54	6.36	2.54	5.1	12.7

\*1 The brackets [ ] indicate the value for the electromagnetic brake type.

\*2 The gearhead internal inertia is the motor shaft converted value.

\*3 The value for 50 times the rotor inertia.

\*4 The resolution for the motor output shaft.

\*5 These values are for operation in the continuous duty region. For operation in the limited duty region, the maximum current is approximately 3 times the value shown.

\*6 The electromagnetic brake is for holding the position when the power supply is OFF. The electromagnetic brake cannot be used to stop the motor. A separate power supply for the electromagnetic brake is also required.

## Speed – Torque Characteristics

NX810□-J5-◇

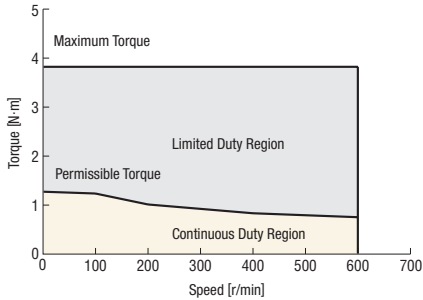

NX810□-J10-◇

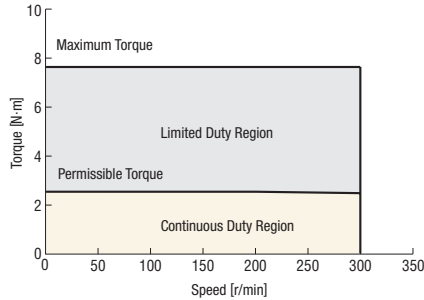

NX810□-J25-◇

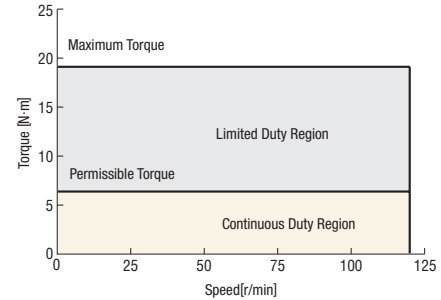

NX820□-J5-◇

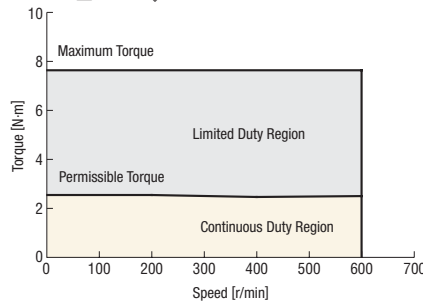

NX820□-J10-◇

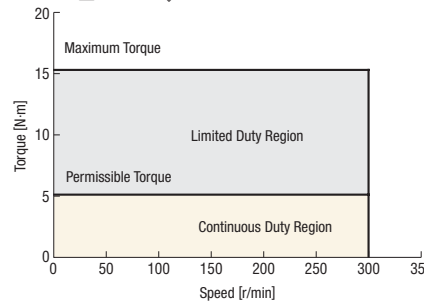

NX820□-J25-◇

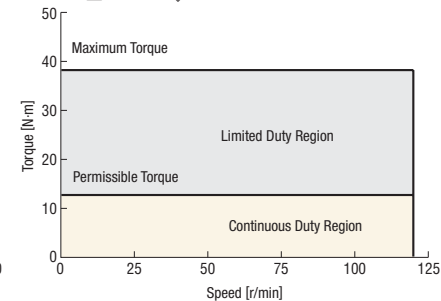

● Either **A** (standard) or **M** (electromagnetic brake type) indicating the motor shaft configuration is entered where the box □ is located within the product name.

Either **A** (single-phase 100-115 VAC) or **C** (single-phase 200-230 VAC/three-phase 200-230 VAC) indicating the power supply voltage is entered where the box □ is located within the product name. A number indicating the desired length of **1** (1 m), **2** (2 m) or **3** (3 m) for the cables included with the product is entered where the box ◇ is located within the product name.

● Depending on the operating conditions, a regeneration unit may be required. Regeneration Unit → Page 43

# PJ Geared Type Frame Size 104 mm

## Specifications RoHS



Product Name	Standard	NX1040AS-J5-◇	NX1040AS-J10-◇	NX1040AS-J25-◇	NX1075AS-J5-◇	NX1075AS-J10-◇	NX1075AS-J25-◇	
		Electromagnetic Brake Type	NX1040MS-J5-◇	NX1040MS-J10-◇	NX1040MS-J25-◇	NX1075MS-J5-◇	NX1075MS-J10-◇	NX1075MS-J25-◇
Rated Output Power	W	400			750			
Motor Permissible Speed	r/min	3000						
Permissible Torque	N·m	5.08	10.2	25.4	9.56	19.1	47.8	
Maximum Torque	N·m	15.2	30.5	76.2	28.7	57.3	143	
Permissible Speed Range	r/min	0~600	0~300	0~120	0~600	0~300	0~120	
Rotor Inertia	J: kg·m <sup>2</sup>	0.535×10 <sup>-4</sup> [0.617×10 <sup>-4</sup> ]*1			0.941×10 <sup>-4</sup> [1.02×10 <sup>-4</sup> ]*1			
Gearhead Internal Inertia*2	J: kg·m <sup>2</sup>	1.31×10 <sup>-4</sup>	0.888×10 <sup>-4</sup>	0.832×10 <sup>-4</sup>	1.31×10 <sup>-4</sup>	0.888×10 <sup>-4</sup>	0.832×10 <sup>-4</sup>	
Permissible Load Inertia*3	J: kg·m <sup>2</sup>	669×10 <sup>-4</sup>	2680×10 <sup>-4</sup>	16700×10 <sup>-4</sup>	1180×10 <sup>-4</sup>	4710×10 <sup>-4</sup>	29400×10 <sup>-4</sup>	
Gear Ratio		5	10	25	5	10	25	
Resolution*4	P/R	100 to 100000 (Factory setting 1000)						
Detector		Absolute Encoder 1 rotation 20 bits, multiple rotations 16 bits						
Backlash	arc minutes (degrees)	3						
Power-Supply Input	Voltage and Frequency	AC Main Power Supply Three-Phase 200-230 VAC -15% to +10% 50/60 Hz						
	DC Control Power Supply	24 VDC±10% 0.8 A						
Electromagnetic Brake*6	Type	Power Off Activated Type						
	Power-Supply Input	24 VDC±10%						
	Power Consumption	8.5						
	Excitation Current	0.35						
	Static Friction Torque	N·m	5.08	10.2	25.4	9.56	19.1	47.8

\*1 The brackets [ ] indicate the specifications for the electromagnetic brake type.

\*2 The gearhead internal inertia is the motor shaft converted value.

\*3 The value for 50 times the rotor inertia.

\*4 The resolution for the motor output shaft.

\*5 These values are for operation in the continuous duty region. For operation in the limited duty region, the maximum current is approximately 3 times the value shown.

\*6 The electromagnetic brake is for holding the position when the power supply is OFF. The electromagnetic brake cannot be used to stop the motor. A separate power supply for the electromagnetic brake is also required.

## Speed – Torque Characteristics

NX1040□S-J5-◇

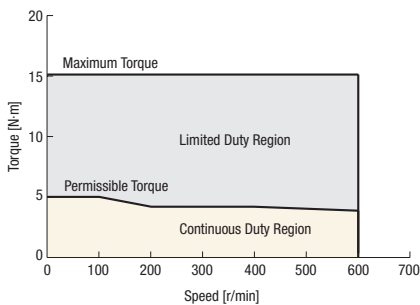

NX1040□S-J10-◇

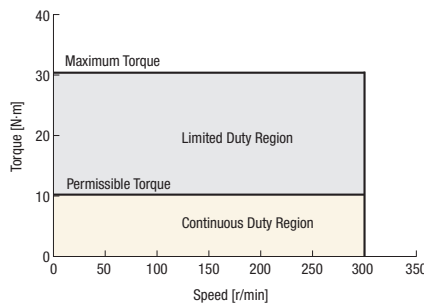

NX1040□S-J25-◇

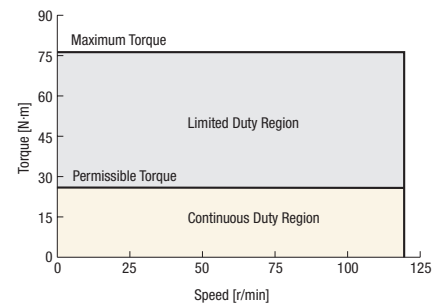

NX1075□S-J5-◇

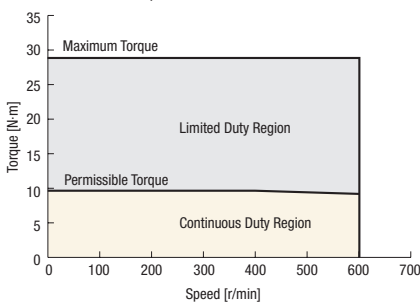

NX1075□S-J10-◇

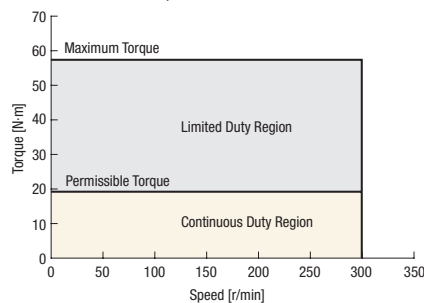

NX1075□S-J25-◇

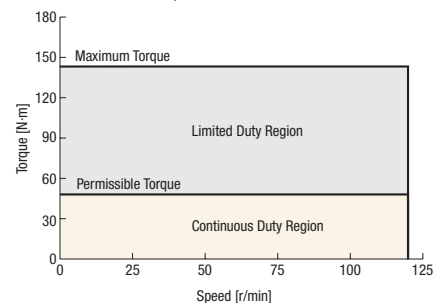

● Either **A** (standard) or **M** (electromagnetic brake type) indicating the motor shaft configuration is entered where the box □ is located within the product name.

A number indicating the desired length of **1** (1 m), **2** (2 m) or **3** (3 m) for the cables included with the product is entered where the box ◇ is located within the product name.

● Depending on the driving conditions, a regeneration unit may be required. Regeneration Unit → Page 43

## Driver Specifications

Interface	Pulse, Analog Speed Command Voltage, Analog Torque Command Voltage
Max. Input Pulse Frequency	Line driver output by programmable controller: 500 kHz (When the pulse duty is 50%) Open collector output by programmable controller: 250 kHz (When the pulse duty is 50%)*
Protective Function	When the following protective functions are activated, an alarm output signal is output and the motor is stopped.  Overflow, Overcurrent Protection, Overheat Protection, Overvoltage Protection, Main Power Supply Error, Undervoltage, Motor Overheat Protection, Sensor Error during Operation, Encoder Communication Error, Overload, Overspeed, Position Range Error, Absolute Position Loss, Command Pulse Error, EEPROM Error, Sensor Error during Initialization, Rotor Rotation during Initialization, Encoder EEPROM Error, Motor Combination Error, ABS Not Supported, No Battery, Regeneration Unit Overheat, Electronic Gear Setting Error
Input Signal	<ul style="list-style-type: none"> <li>Photocoupler Input, Input Resistance: 3 kΩ Input Signal Voltage: 4.75 to 26.4 VDC (S-ON, CLR/ALM-RST/P-CK, P-REQ/BRAKE, TL/W-RESET, M0, M1, P-PRESET/M2, FREE)</li> <li>Photocoupler Input, Input Resistance: 2.7 kΩ Input Voltage: 21.6 to 26.4 VDC (CW+24 V/PLS+24 V, CCW+24 V/DIR+24 V)</li> <li>Photocoupler Input, Input Resistance: 200 Ω Input Voltage: 3 to 5.25 VDC (CW/PLS, CCW/DIR)</li> <li>Analog Input</li> </ul> Set with Internal Potentiometer (VR1, VR2) Analog Input Voltage ±10 VDC Input Impedance 15 kΩ Set with External Potentiometer 20 kΩ 1/4 W (V-REF, T-REF, P-VREF, P-TREF)
Output Signal	<ul style="list-style-type: none"> <li>Photocoupler and Open Collector Output External use conditions: 30 VDC, 10 mA max. (ALM, WNG/MOVE/MBC, END/VA, READY/ALO/P-OUTR, TLC/VLC/AL1/P-OUT0, ZSG2/NEAR/ZV/AL2/P-OUT1)</li> <li>Line Driver Output</li> </ul> External use condition: Connect a terminating resistor of 100 Ω min. between the line receiver inputs. (ASG, BSG, ZSG1) <ul style="list-style-type: none"> <li>Analog Monitor Output Analog Output Voltage ±10 VDC Output Impedance 1 kΩ (V-MON, T-MON, SG)</li> </ul>
Other Functions	Position Control, Speed Control, Torque Control, Tension Control Automatic Tuning, Damping Control Function (7 to 30 Hz), Position Preset Function, Current Position Output Function, Torque Limiting Function Pulse Input Mode (2-Pulse Input, 1-Pulse Input), Analog Monitor Output Function (Speed, Torque), Absolute System Enabled/Disabled Warning Output Function, (Overflow, Overheat, Overvoltage, Main Power Supply, Undervoltage, Battery Undervoltage, Overload, Overspeed, Absolute Position Loss, Electronic Gear Setting Error)
Extended Functions [When using the separately-sold control module <b>(OPX-2A)</b> or the data setting software <b>(MEXE02)</b> ]	For details on extended functions, refer to page 32.

\*The values when the separately-sold general-purpose cable **(CC36D1-1)** is used. General-Purpose Cable → Page 40

## Position Control Mode Specifications

Item	Factory Setting	When Using Extended Functions
Command Mode	Pulse Input Mode Select one of the following. <ul style="list-style-type: none"> <li>2-Pulse Input Mode (Factory setting)</li> <li>1-Pulse Input Mode</li> </ul>	Pulse Input Mode Select one of the following. <ul style="list-style-type: none"> <li>2-Pulse Input Mode</li> <li>1-Pulse Input Mode</li> <li>Phase Difference Input Mode (Internal parameter setting)</li> </ul>
Max. Input Pulse Frequency	Line driver output by programmable controller: 500 kHz (When the pulse duty is 50%) Open collector output by programmable controller: 250 kHz (When the pulse duty is 50%)*1	
Resolution	1000 P/R	100 to 100000 P/R
Encoder Output Resolution	1000 P/R	100 to 10000 P/R
Damping Control Frequency	Disabled/7 to 30 Hz (Internal potentiometer VR1)	Can be set with ① and ② below with 1 analog type and 3 internal parameters for a total of 4 types or with 4 internal parameters. ①Internal Potentiometer VR1 1 Type ②Set with 3 or 4 Internal Parameters Disabled/7 to 30 Hz (Internal potentiometer VR1) Disabled/7 to 100 Hz (Internal parameter setting)
Absolute System Position Control Range	-2,147,483,648 to 2,147,483,647 pulses	
Current Position Output	2-bit Serial Output	
Tuning	Automatic tuning only <Automatic> The rigidity setting (SW2) is selected from 16 levels. The load inertia is estimated and the gain is automatically adjusted according to the rigidity setting.	Automatic tuning, semi-auto tuning, and manual tuning can be selected. <Automatic> Select the rigidity setting (SW2 or internal parameter) from 16 levels. The load inertia is estimated and the gain is automatically adjusted according to the rigidity setting. <Semi-Auto> Select the rigidity setting (SW2 or internal parameter) from 16 levels. Input the load inertia ratio. <Manual> Select the rigidity setting (SW2 or internal parameter) from 16 levels. Input the load inertia ratio. All gain can be set manually.
Torque Limiting	0 to 300% (The rated torque is 100%.) External Potentiometer*2 (T-REF)	0 to 300% (The rated torque is 100%. Can be set in steps of 1% with an internal parameter.) Set with External Potentiometer*2 (T-REF), Internal Parameter

● Using extended functions requires the separately-sold control module **(OPX-2A)** or the data setting software **(MEXE02)**.

\*1 The values when the separately-sold general-purpose cable **(CC36D1-1)** is used. General-Purpose Cable → Page 40

\*2 Accessory sets are available (sold separately). Accessory Set → Page 43

## Speed Control Mode Specifications

Item	Factory Setting	When Using Extended Functions
Command Mode	2 speeds can be set with ① and ② below. ①Internal Potentiometer VR1 1 Speed ②External Potentiometer* V-REF (Selected with potentiometer or external DC voltage) 1 Speed · Set with potentiometer: 20 kΩ 1/4 W · Set by external DC voltage: ±0 to 10 VDC Input impedance 15 kΩ	Can be set with ①, ②, and ③ below with 2 analog speeds and 6 speeds set with internal parameters for a total of 8 speeds or with 8 speeds set with internal parameters. ①Internal Potentiometer VR1 1 Speed ②External Potentiometer* V-REF (Selected with potentiometer or external DC voltage) 1 Speed · Set with potentiometer: 20 kΩ 1/4 W · Set by external DC voltage: ±0 to 10 VDC Input impedance 15 kΩ ③Internal Parameter Settings 6 or 8 Speeds
Speed Setting Range	10 to 5500 r/min (Analog speed setting VR1, V-REF)	10 to 5500 r/min (Analog speed setting VR1, V-REF) 1 to 5500 r/min (Internal parameter setting)
Acceleration/Deceleration Time Setting Range	5 ms to 10 sec./ (1000 r/min) (Acceleration and deceleration time per 1000 r/min) Internal Potentiometer (VR2)	5 ms to 10 sec./ (1000 r/min) (Acceleration and deceleration time per 1000 r/min) The setting method can be selected: either an internal potentiometer (VR2) or internal parameter.
Speed Regulation	Load	±0.05% max. (0 to rated torque, rated speed, rated voltage, normal temperature)
	Voltage	±0.05% max. (Power-supply input voltage range, at 3000 r/min no load)
Speed Regulation	Temperature	±0.5% max. (With analog speed setting VR1, V-REF) Common Conditions Operating Ambient Temperature 0 to +50°C, Rated Speed, No Load, Rated Voltage
	Temperature	±0.5% max. (With analog speed setting VR1, V-REF) Common Conditions Operating Ambient Temperature 0 to +50°C, Rated Speed, No Load, Rated Voltage
Torque Limiting	0 to 300% (100% is rated torque.) Set with External Potentiometer* (T-REF)	0 to 300% (100% is rated torque. Can be set in steps of 1% with an internal parameter.) Set with External Potentiometer* (T-REF), Internal Parameter
Operation When Motor is Stopped	—	The operation when the motor is stopped can be selected · Motor Non-Excitation · Position Holding by Servo Control Stopped (Motor excitation)
Tuning	Automatic tuning only <Automatic> The rigidity setting (SW2) is selected from 16 levels. The load inertia is estimated and the gain is automatically adjusted according to the rigidity setting.	Automatic tuning, semi-auto tuning, and manual tuning can be selected. When operation when the motor is stopped is set to "Position holding by servo control stopped", the position loop gain and speed feed-forward are set just like position control. <Automatic> Select the rigidity setting (SW2 or internal parameter) from 16 levels. The load inertia is estimated and the gain is automatically adjusted according to the rigidity setting. <Semi-Auto> Select the rigidity setting (SW2 or internal parameter) from 16 levels. Input the load inertia ratio. <Manual> Select the rigidity setting (SW2 or internal parameter) from 16 levels. Input the load inertia ratio. All gain can be set manually.
Encoder Output Resolution	1000 P/R	100 to 10000 P/R

● Using extended functions requires the separately-sold control module (**OPX-2A**) or the data setting software (**MEXE02**).

\*Accessory sets are available (sold separately). Accessory Set → Page 43

## Torque Control Mode Specifications

Item	Factory Setting	When Using Extended Functions
Command Mode	2 types can be set with ① and ② below. ①Internal Potentiometer VR1 1 Type ②External Potentiometer* T-REF (Selected with potentiometer or external DC voltage) 1 Type · Set with potentiometer: 20 kΩ 1/4 W · Set by external DC voltage: ±0 to 10 VDC Input impedance 15 kΩ	Can be set with ①, ②, and ③ below with 2 analog types and 6 types set with internal parameters for a total of 8 types or with 8 internal parameters. ①Internal Potentiometer VR1 1 Type ②External Potentiometer* T-REF (Selected with potentiometer or external DC voltage) 1 Type · Set with potentiometer: 20 kΩ 1/4 W · Set by external DC voltage: ±0 to 10 VDC Input impedance 15 kΩ ③Set with 6 or 8 Internal Parameters
Torque Control Range	0 to 300% (100% is rated torque.)	0 to 300% (100% is rated torque. Can be set in steps of 1% with an internal parameter.)
Speed Limit	0 to 5500 r/min Set with internal potentiometer (VR2) or external potentiometer* (V-REF)	0 to 5500 r/min (Can be set in 1 r/min steps with an internal parameter.) Set with internal potentiometer (VR2) or external potentiometer* (V-REF), or with an internal parameter
Encoder Output Resolution	1000 P/R	100 to 10000 P/R

● Using extended functions requires the separately-sold control module (**OPX-2A**) or the data setting software (**MEXE02**).

\*Accessory sets are available (sold separately). Accessory Set → Page 43



## Tension Control Mode Specifications

Item	Factory Setting	When Using Extended Functions
Command Mode	2 types can be set with ① and ② below. ① Internal Potentiometer VR1 1 Type ② External Potentiometer* T-REF (Selected with potentiometer or external DC voltage) 1 Type • Set with potentiometer: 20 kΩ 1/4 W • Set by external DC voltage: ±0 to 10 VDC Input impedance 15 kΩ	Can be set with ①, ②, and ③ below with 2 analog types and 6 types set with internal parameters for a total of 8 types or with 8 internal parameters. ① Internal Potentiometer VR1 1 Type ② External Potentiometer* T-REF (Selected with potentiometer or external DC voltage) 1 Type • Set with potentiometer: 20 kΩ 1/4 W • Set by external DC voltage: ±0 to 10 VDC Input impedance 15 kΩ ③ Set with 6 or 8 Internal Parameters
Control Method	Simple Mode	The tension is controlled to be constant when the feed speed is constant.
	High Function Mode I	—
	High Function Mode II	—
Tension Control Range	0 to 100% (100% is rated torque.)	0 to 100% (100% is rated torque. Can be set in steps of 1%.)
Speed Limit	0 to 5500 r/min Set with internal potentiometer (VR2), external potentiometer* (V-REF)	0 to 5500 r/min (Can be set in 1 r/min steps.) Set with internal potentiometer (VR2) or external potentiometer* (V-REF), or with an internal parameter
Minimum Speed	The minimum speed for simple mode can be selected with SW2. The setting range has 16 levels from 0 (10 r/min) to F (3000 r/min).	
Encoder Output Resolution	1000 P/R	100 to 10000 P/R

● Using extended functions requires the separately-sold control module (**OPX-2A**) or the data setting software (**MEXE02**).

\*Accessory sets are available (sold separately). Accessory Set → Page 43

## General Specifications

Specifications	Motor	Driver
Insulation Class	Class B (130°C)	—
Insulation Resistance	100 MΩ min. when measured with a 500 VDC megger between the following locations: • Case — Motor Windings • Case — Electromagnetic Brake Windings	100 MΩ min. when measured with a 500 VDC megger between the following locations: • PE terminal — AC Main Power Supply Connector, Motor Connector • DC Control Power Supply Connector, I/O Connector, Encoder Connector, Control Module Connector, Battery Connector — AC Main Power Supply Connector, Motor Connector
Dielectric Voltage	No abnormality is judged with the following application for 1 minute: • Case — Motor Windings 1.5 kVAC 50 Hz or 60 Hz • Case — Electromagnetic Brake Windings 1.0 kVAC 50 Hz or 60 Hz	No abnormality is judged with the following application for 1 minute: • PE terminal — AC Main Power Supply Connector, Motor Connector 1.5 kVAC 50 Hz or 60 Hz • DC Control Power Supply Connector, I/O Connector, Encoder Connector, Control Module Connector, Battery Connector — AC Main Power Supply Connector, Motor Connector 1.8 kVAC 50 Hz or 60 Hz
Operating Environment (In operation)	Ambient Temperature	0 to +40°C (Non-freezing)
	Ambient Humidity	85% max. (Non-condensing)
	Atmosphere	No corrosive gases. Must not be exposed to oil or other liquids.
Degree of Protection	IP65 (Standard type, electromagnetic brake type, <b>PS</b> geared type: excluding installation surface and connector locations. <b>PJ</b> geared type: excluding connector locations)	IP20
Shaft Runout	0.05 T. I. R. (mm)*1	—
Concentricity of Installation Pilot to the Shaft	0.075 T. I. R. (mm)*1	—
Perpendicularity of Installation Surface to the Shaft	0.075 T. I. R. (mm)*1	—

\*1 T. I. R. (Total Indicator Reading): The total dial gauge reading when the measurement section is rotated 1 rotation centered on the reference axis.

\*2 If the driver's ambient temperature exceeds 40°C, hold the continuous motor output below the derating curve in the figure below.

### Note

● Do not perform the insulation resistance test or dielectric voltage withstand test while the motor and driver are connected.  
Also, do not conduct these tests on the motor encoder section.

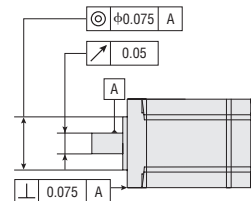

## Motor Continuous Output Derating Curve

If the driver's operating ambient temperature exceeds 40°C, hold the continuous motor output below the derating curve in the figure below. There is no need for derating for the types with rated output power of 50 W or 400 W.

### ◇ Rated Output Power 100 W

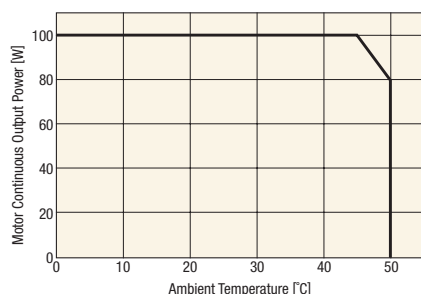

### ◇ Rated Output Power 200 W

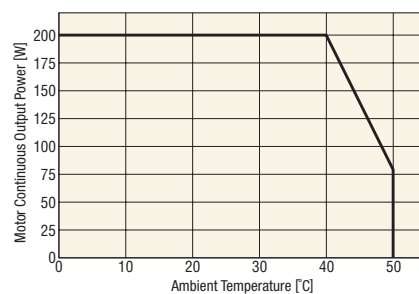

### ◇ Rated Output Power 750 W

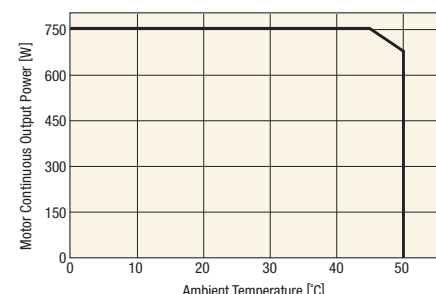

## Standard and CE Marking

Product	Applicable Standards	Certification Body	Standards File Number	CE Marking
Motor	UL 1004*1 CSA C22.2 No. 100*1	UL	E336472	Low Voltage Directive EMC Directive
	EN 60034-1*1	TÜV	R 50124202	
	EN 60034-5 EN 60664-1	Component Conforming to Safety Standards		
Driver	UL 508C*2 CSA C22.2 No. 14*2	UL	E171462	
	EN 50178	Component Conforming to Safety Standards		
	EN 61800-5-1*2	TÜV	R 50124205	

\*1 NXM620, NXM810, NXM820, NXM920 only.

\*2 Excluding NXD75-S.

- The UL Standard (UL508C) stipulates a maximum surrounding air temperature of 50°C.
- When connecting a 24 VDC power supply, use a Class 2 (UL Standards) power supply (24 VDC CLASS2).
- The UL short circuit test is performed at an effective current value of 5000 A and 240 VDC.
- The EMC value changes according to the wiring and layout. Therefore, the final check must be done with the product incorporated in the user's device.

## Permissible Overhung Load, Permissible Thrust Load and Permissible Moment Load

Type	Frame Size	Type	Gear Ratio	Permissible Overhung Load [N] Distance from Shaft End [mm]							Permissible Thrust Load [N]	Permissible Moment Load [N·m]	
				0	5	10	15	20	25	30			35
Standard Type	42 mm	<b>NX45</b> <b>NX410</b>	-	81	88	95	104	-	-	-	-	59	-
	60 mm	<b>NX620</b> <b>NX640</b>		230	245	262	281	304	-	-	-	98	-
	85 mm	<b>NX975</b>		376	392	408	426	446	467	491	-	147	-
PS Geared Type	60 mm	<b>NX65</b> <b>NX610</b>	5	200	220	250	280	320	-	-	-	100	-
			10	250	270	300	340	390	-	-	-		
			25	330	360	400	450	520	-	-	-		
	90 mm	<b>NX920</b> <b>NX940</b>	5, 10	480	540	600	680	790	-	-	-	300	-
PJ Geared Type	80 mm	<b>NX810</b> <b>NX820</b>	5	300	330	350	380	400	430	460	500	300	16
			10	450	480	510	540	570	610	650	700	400	33
			25	680	710	750	780	840	900	950	1000	600	60
	104 mm	<b>NX1040</b> <b>NX1075</b>	5	650	700	730	750	800	830	880	920	500	30
			10	900	950	1000	1050	1100	1180	1230	1300	650	66
			25	1350	1400	1480	1550	1600	1650	1750	1850	1000	120

## PJ Geared Type Permissible Moment Load

When installing an arm or table on the flange face, if an eccentric load is applied, calculate the moment load with the following formula.

Moment load:  $M [N\cdot m] = F [N] \times L [m]$

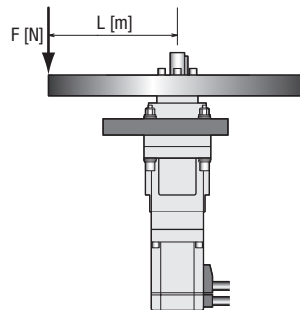

## Dimensions (Unit = mm)

### ● Motor

### ◇ Standard Type

### Frame Size 42 mm

Product Name	Motor Product Name	L	Mass kg	CAD
<b>NX45A</b> □-◇	NXM45A	74.5	0.5	C210
<b>NX410A</b> □-◇	NXM410A	88.8	0.6	C211

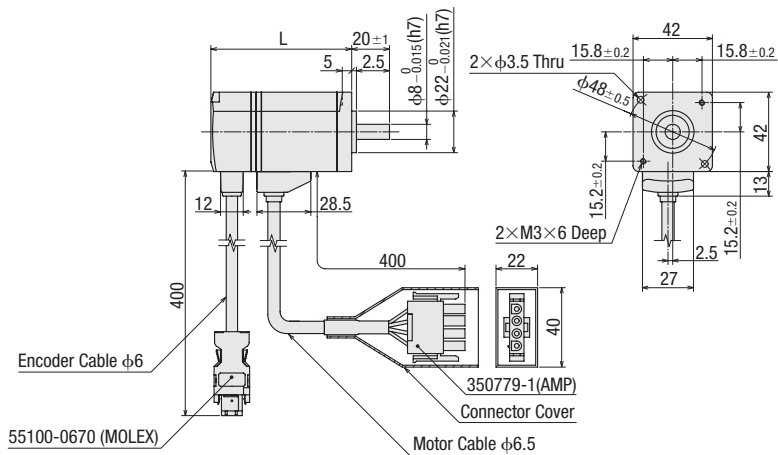

### Frame Size 42 mm Electromagnetic Brake Type

Product Name	Motor Product Name	L	Mass kg	CAD
<b>NX45M</b> □-◇	NXM45M	110.5	0.7	C212
<b>NX410M</b> □-◇	NXM410M	124.8	0.8	C213

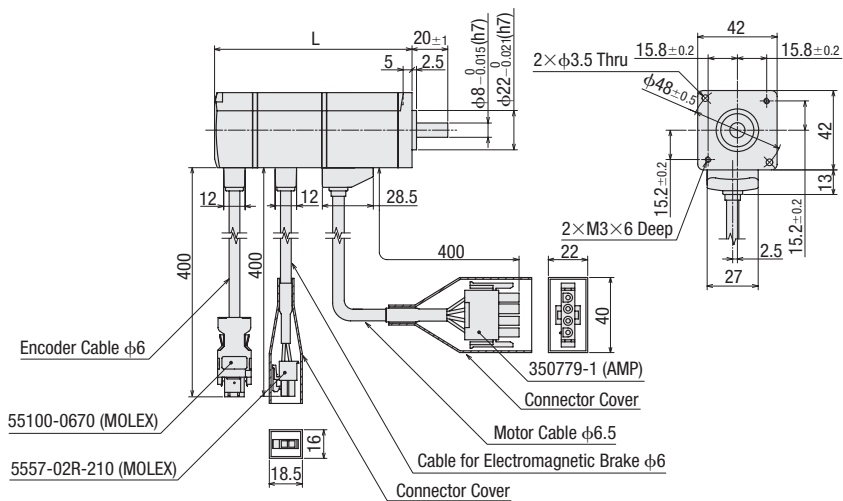

### Frame Size 60 mm

Product Name	Motor Product Name	L	Mass kg	CAD
<b>NX620A</b> □-◇	NXM620A	84.5	1	C203
<b>NX640AS</b> -◇	NXM640A	114.8	1.5	C216

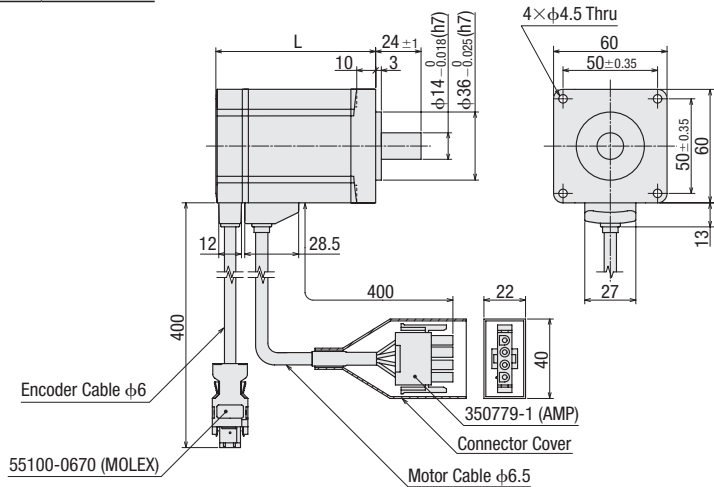

● Either **A** (single-phase 100-115 VAC) or **C** (single-phase 200-230 VAC/three-phase 200-230 VAC) indicating the power supply voltage is entered where the box □ is located within the product name.  
 A number indicating the desired length of **1** (1 m), **2** (2 m) or **3** (3 m) for the cables included with the product is entered where the box ◇ is located within the product name.

### Frame Size 60 mm Electromagnetic Brake Type

Product Name	Motor Product Name	L	Mass kg	CAD
<b>NX620M</b> <span style="border: 1px solid black; padding: 0 2px;"> </span> <span style="border-left: 1px solid black; border-right: 1px solid black; padding: 0 2px;"> </span>	NXM620M	126.3	1.5	C204
<b>NX640MS</b> <span style="border-left: 1px solid black; border-right: 1px solid black; padding: 0 2px;"> </span>	NXM640M	156.6	2	C217

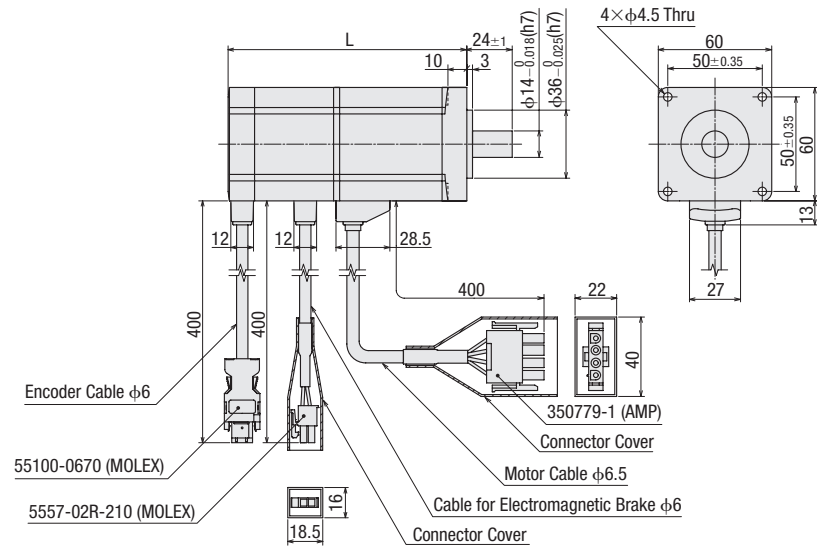

### Frame Size 85 mm

Product Name	Motor Product Name	Mass kg	CAD
<b>NX975AS</b> <span style="border-left: 1px solid black; border-right: 1px solid black; padding: 0 2px;"> </span>	NXM975A	3.1	C218

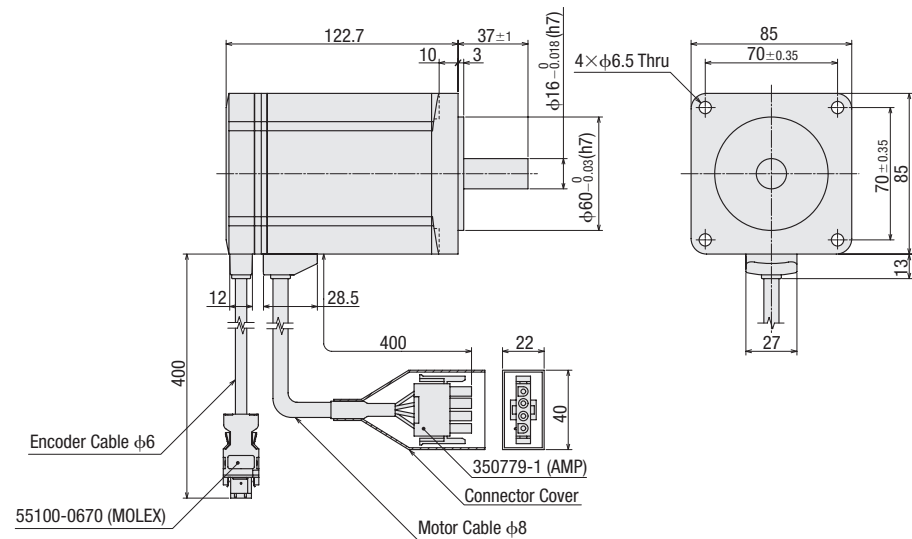

### Frame Size 85 mm Electromagnetic Brake Type

Product Name	Motor Product Name	Mass kg	CAD
<b>NX975MS</b> <span style="border-left: 1px solid black; border-right: 1px solid black; padding: 0 2px;"> </span>	NXM975M	4.1	C219

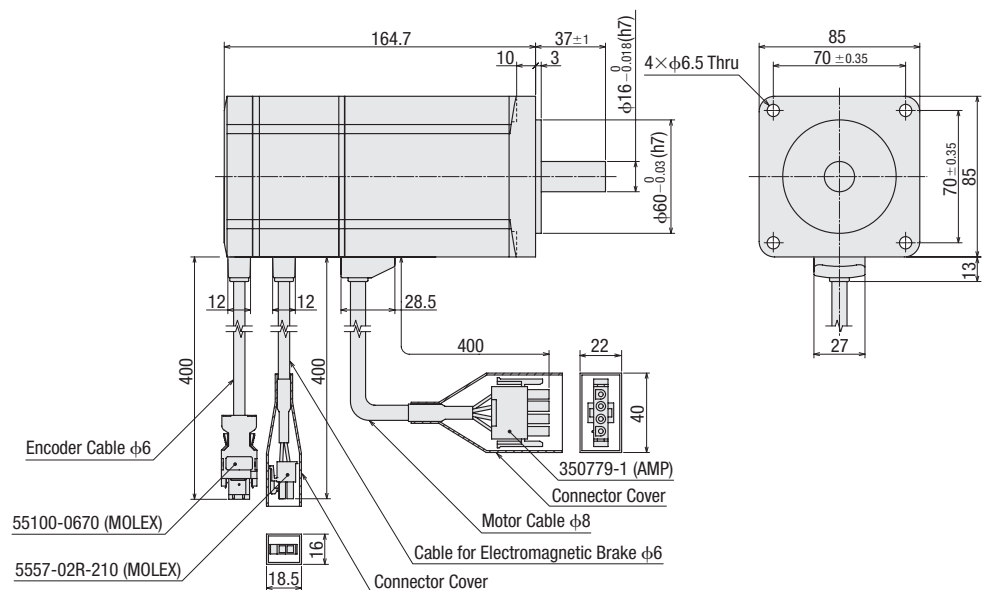

● Either **A** (single-phase 100-115 VAC) or **C** (single-phase 200-230 VAC/three-phase 200-230 VAC) indicating the power supply voltage is entered where the box   is located within the product name. A number indicating the desired length of **1** (1 m), **2** (2 m) or **3** (3 m) for the cables included with the product is entered where the box   is located within the product name.

◆ **PS Geared Type**  
**Frame Size 60 mm**

Product Name	Motor Product Name	Gear Ratio	L1	L2	Mass kg	CAD
<b>NX65A</b> □-PS □-◇	NXM65A-PS □	<b>5, 10</b>	43	132.5	1.15	C241
		<b>25</b>	63.2	153	1.45	C242
<b>NX610A</b> □-PS □-◇	NXM610A-PS □	<b>5, 10</b>	43	147	1.25	C243
		<b>25</b>	63.2	167	1.55	C244

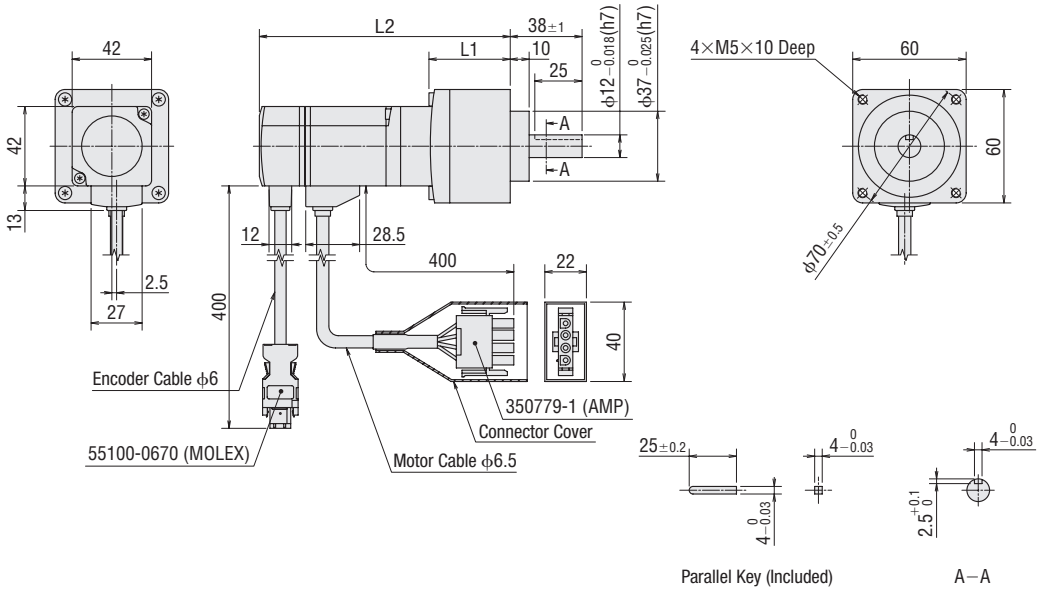

**Frame Size 60 mm Electromagnetic Brake Type**

Product Name	Motor Product Name	Gear Ratio	L1	L2	Mass kg	CAD
<b>NX65M</b> □-PS □-◇	NXM65M-PS □	<b>5, 10</b>	43	168.5	1.35	C245
		<b>25</b>	63.2	189	1.65	C246
<b>NX610M</b> □-PS □-◇	NXM610M-PS □	<b>5, 10</b>	43	183	1.45	C247
		<b>25</b>	63.2	203	1.75	C248

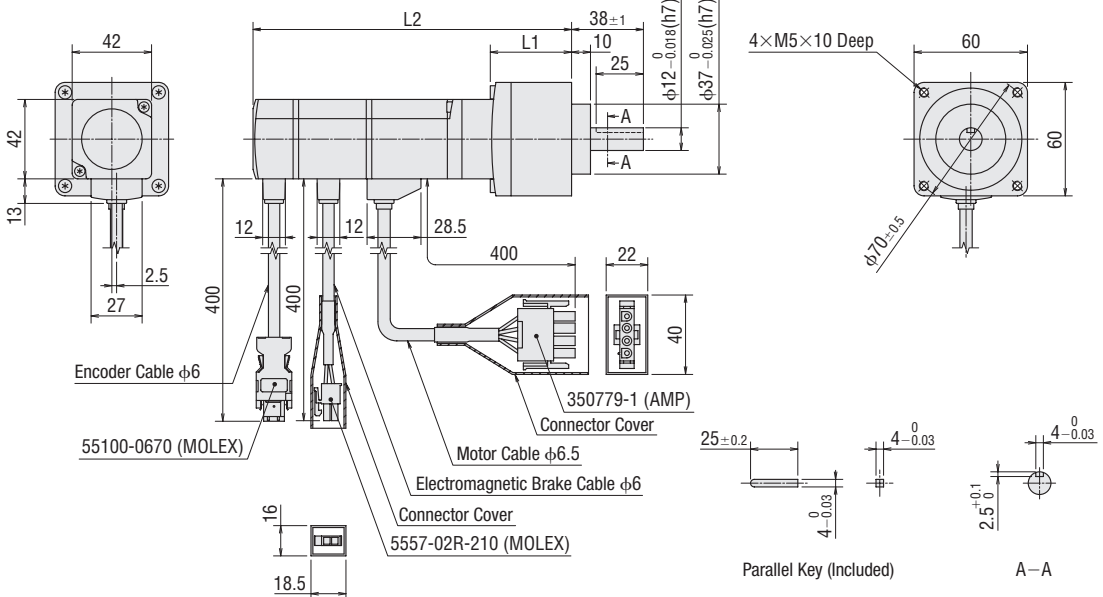

● Either **A** (single-phase 100-115 VAC) or **C** (single-phase 200-230 VAC/three-phase 200-230 VAC) indicating the power supply voltage is entered where the box □ is located within the product name.  
 A number indicating the gear ratio is entered where the box □ is located within the product name.  
 A number indicating the desired length of **1** (1 m), **2** (2 m) or **3** (3 m) for the cables included with the product is entered where the box ◇ is located within the product name.



◆ **PS Geared Type**  
Frame Size 90 mm

Product Name	Motor Product Name	Gear Ratio	L1	L2	Mass kg	CAD
<b>NX920A</b> <input type="checkbox"/> - <b>PS</b> <input type="checkbox"/> - <input type="checkbox"/> ◆	NXM920A-PS <input type="checkbox"/>	<b>5, 10</b>	61	164.5	3	C249
		<b>25</b>	88.3	192	3.9	C250
<b>NX940AS</b> - <b>PS</b> <input type="checkbox"/> - <input type="checkbox"/> ◆	NXM940A-PS <input type="checkbox"/>	<b>5, 10</b>	61	195	3.5	C251
		<b>25</b>	88.3	222	4.4	C252

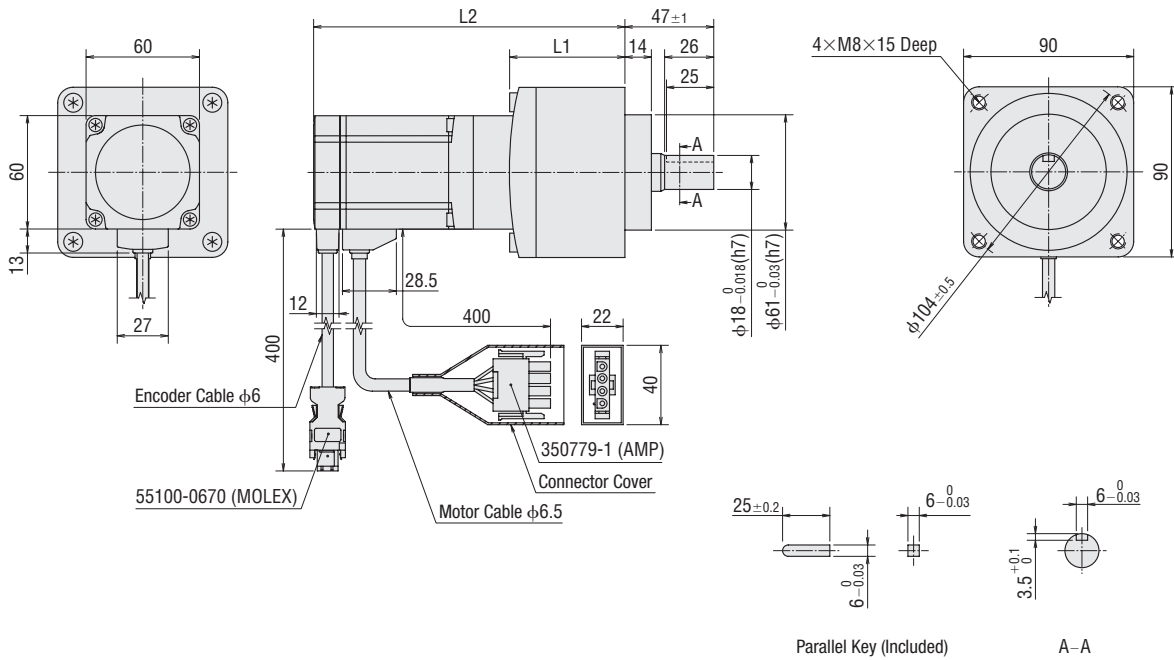

Frame Size 90 mm Electromagnetic Brake Type

Product Name	Motor Product Name	Gear Ratio	L1	L2	Mass kg	CAD
<b>NX920M</b> <input type="checkbox"/> - <b>PS</b> <input type="checkbox"/> - <input type="checkbox"/> ◆	NXM920M-PS <input type="checkbox"/>	<b>5, 10</b>	61	206.5	3.5	C253
		<b>25</b>	88.3	233.5	4.4	C254
<b>NX940MS</b> - <b>PS</b> <input type="checkbox"/> - <input type="checkbox"/> ◆	NXM940M-PS <input type="checkbox"/>	<b>5, 10</b>	61	236.5	4	C255
		<b>25</b>	88.3	264	4.9	C256

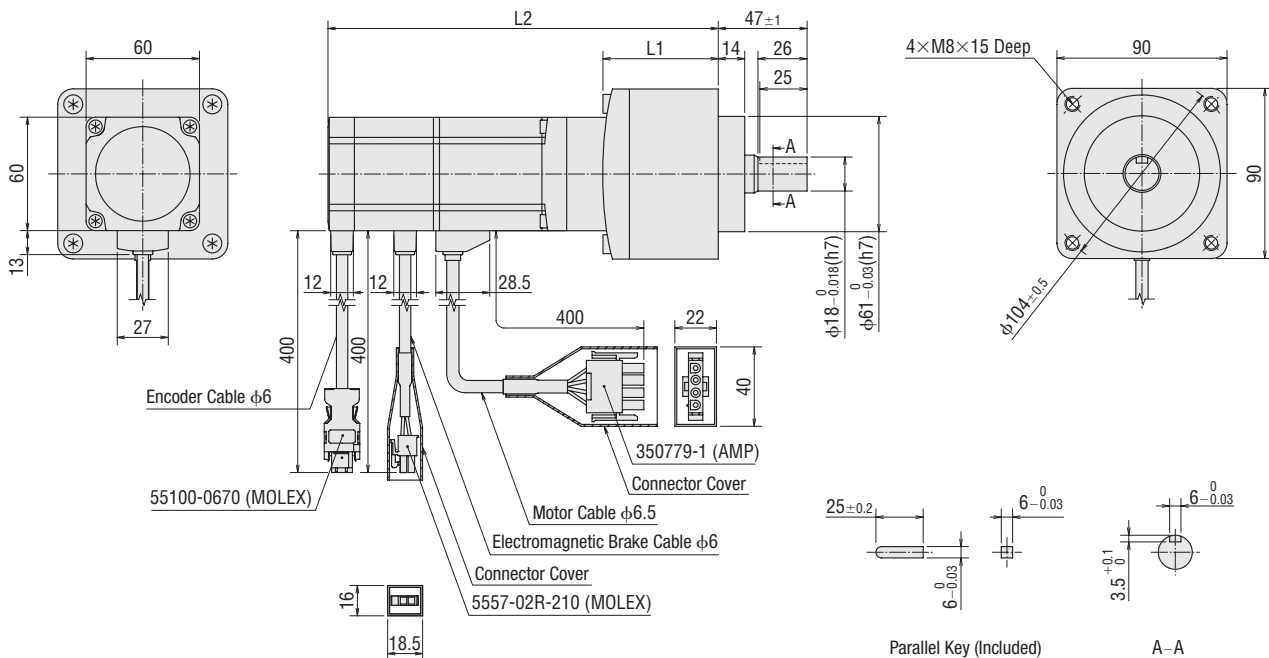

● Either **A** (single-phase 100-115 VAC) or **C** (single-phase 200-230 VAC/three-phase 200-230 VAC) indicating the power supply voltage is entered where the box  is located within the product name.  
 A number indicating the gear ratio is entered where the box  is located within the product name.  
 A number indicating the desired length of **1** (1 m), **2** (2 m) or **3** (3 m) for the cables included with the product is entered where the box  is located within the product name.

◇ **PJ Geared Type**

Frame Size 80 mm

Product Name	Motor Product Name	Gear Ratio	L1	L2	Mass kg	CAD
<b>NX810A</b> □-J □-◇	NXM810A-J □	<b>5, 10, 25</b>	71.2	156.2	3.6	C205
<b>NX820A</b> □-J □-◇	NXM820A-J □		84.5	169.5	3.8	C206

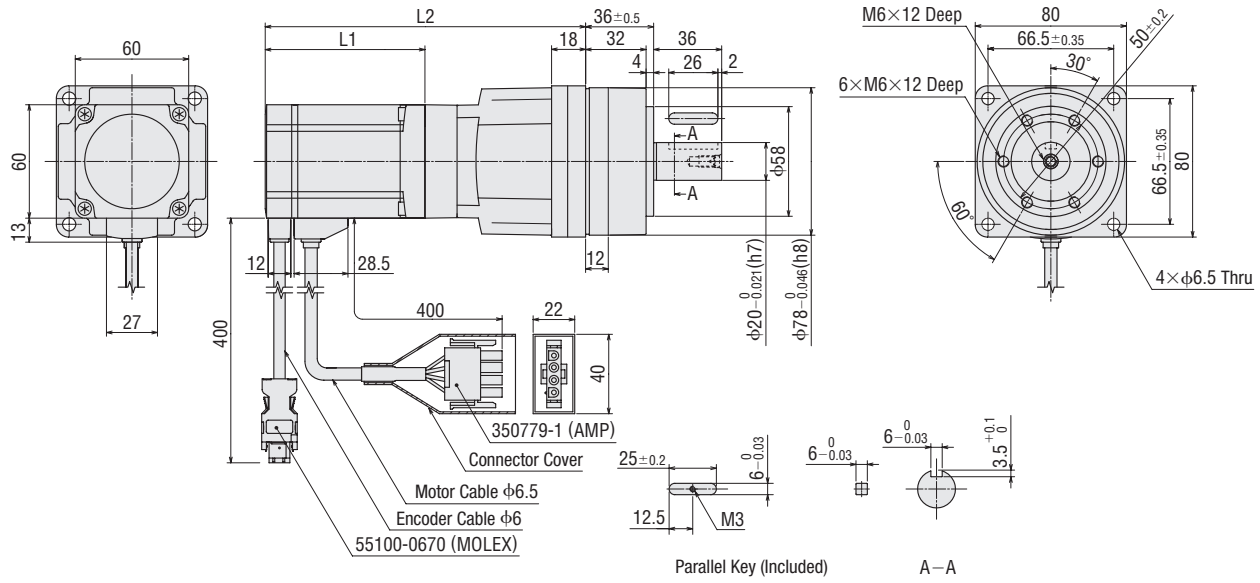

Frame Size 80 mm Electromagnetic Brake Type

Product Name	Motor Product Name	Gear Ratio	L1	L2	Mass kg	CAD
<b>NX810M</b> □-J □-◇	NXM810M-J □	<b>5, 10, 25</b>	113	198	4.1	C207
<b>NX820M</b> □-J □-◇	NXM820M-J □		126.3	211.3	4.3	C208

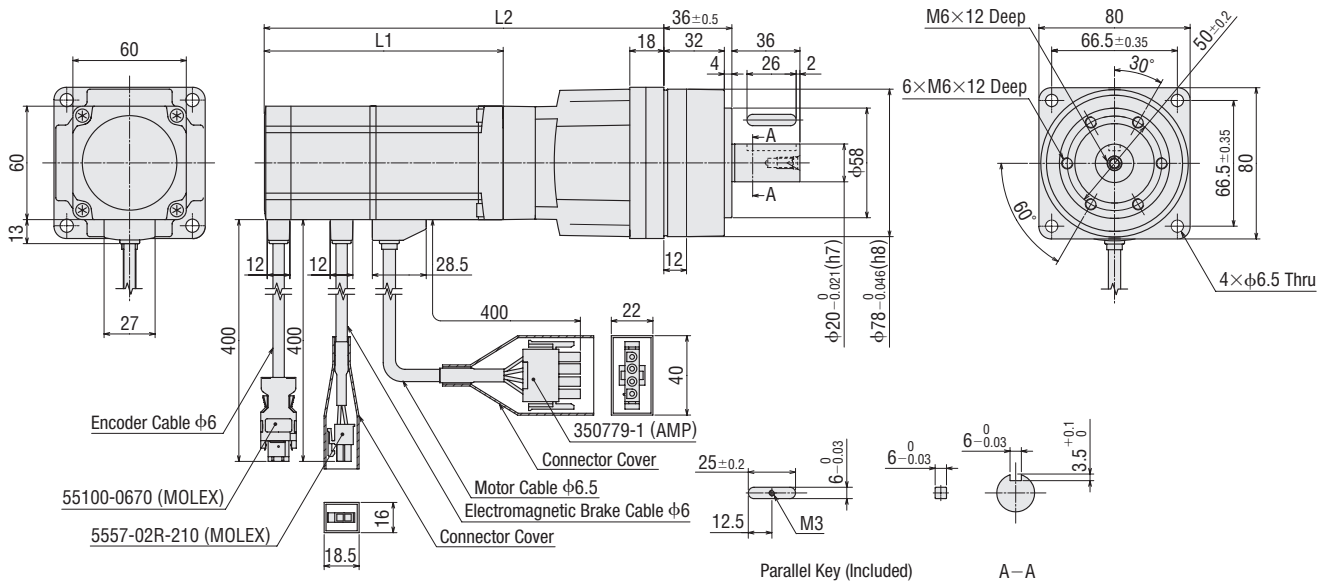

● Either **A** (single-phase 100-115 VAC) or **C** (single-phase 200-230 VAC/three-phase 200-230 VAC) indicating the power supply voltage is entered where the box □ is located within the product name.  
 A number indicating the gear ratio is entered where the box □ is located within the product name.  
 A number indicating the desired length of **1** (1 m), **2** (2 m) or **3** (3 m) for the cables included with the product is entered where the box ◇ is located within the product name.

◇PJ Geared Type  
Frame Size 104 mm

Product Name	Motor Product Name	Gear Ratio	L1	L2	Mass kg	CAD
<b>NX1040AS-J</b> □-◇	NXM1040A-J□	<b>5, 10</b>	92.8	201.8	7.7	C220
		<b>25</b>			8.2	
<b>NX1075AS-J</b> □-◇	NXM1075A-J□	<b>5, 10</b>	122.7	231.7	8.6	C221
		<b>25</b>			9.1	

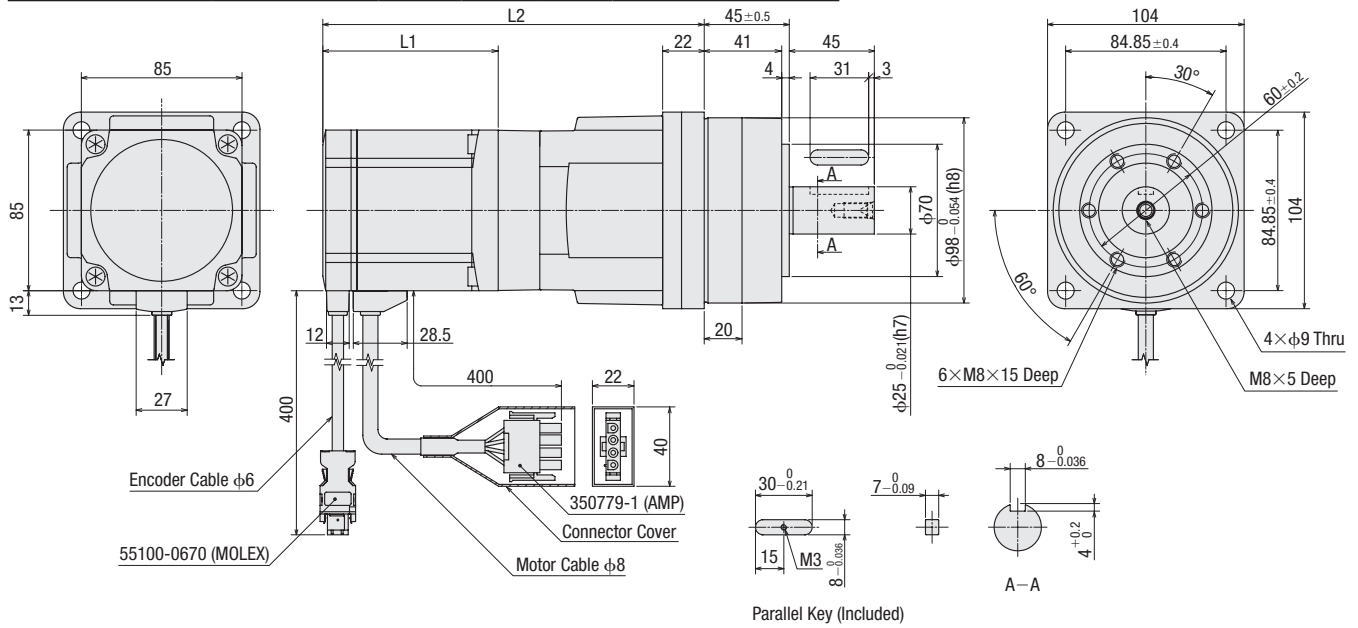

Frame Size 104 mm Electromagnetic Brake Type

Product Name	Motor Product Name	Gear Ratio	L1	L2	Mass kg	CAD
<b>NX1040MS-J</b> □-◇	NXM1040M-J□	<b>5, 10</b>	134.8	243.8	8.6	C222
		<b>25</b>			9.1	
<b>NX1075MS-J</b> □-◇	NXM1075M-J□	<b>5, 10</b>	164.7	273.7	9.6	C223
		<b>25</b>			10.1	

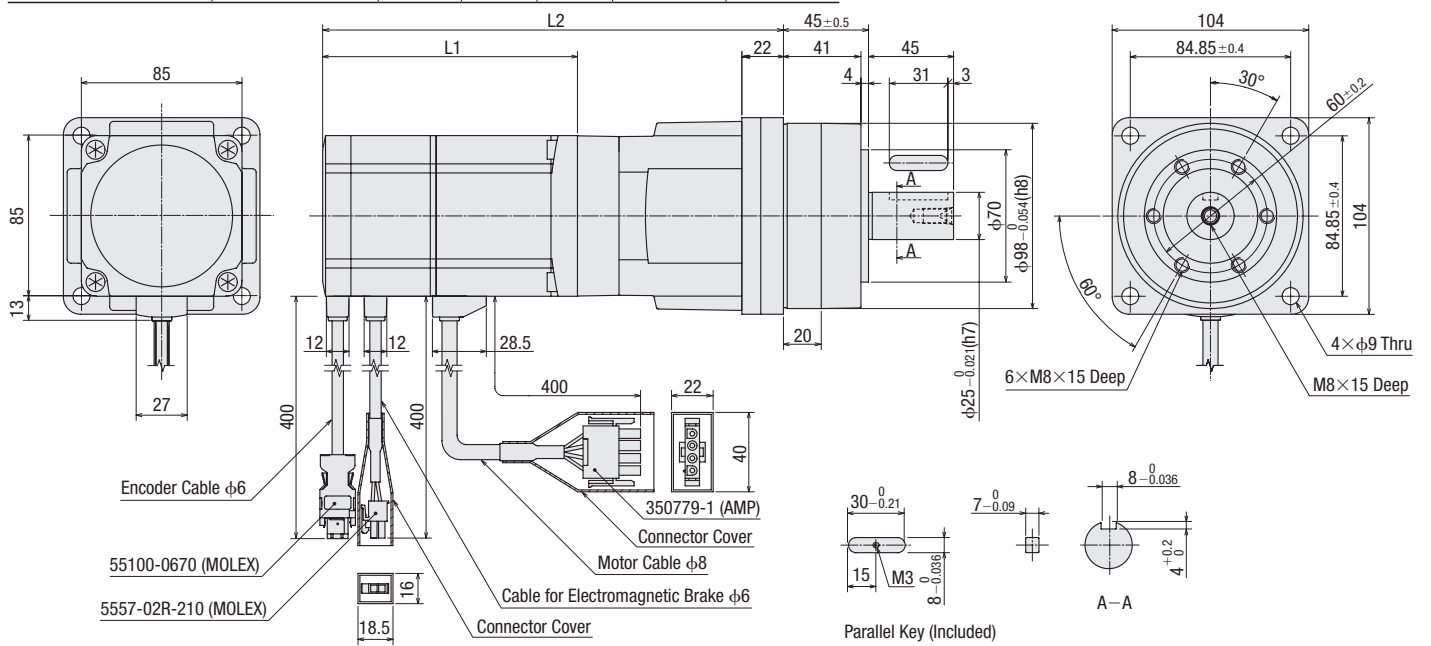

● A number indicating the gear ratio is entered where the box □ is located within the product name.

A number indicating the desired length of 1 (1 m), 2 (2 m) or 3 (3 m) for the cables included with the product is entered where the box ◇ is located within the product name.

● Driver

Product names: NXD20-A, NXD20-C

Mass: 0.9 kg

CAD C209

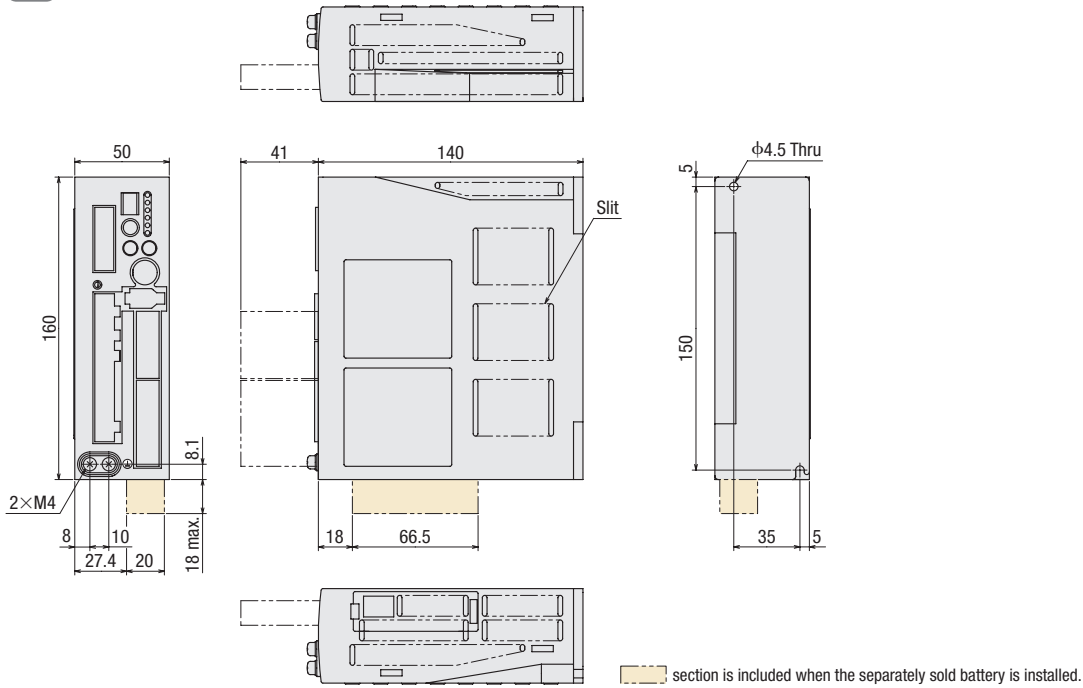

Product name: NXD75-S

Mass: 1.6 kg

CAD C224

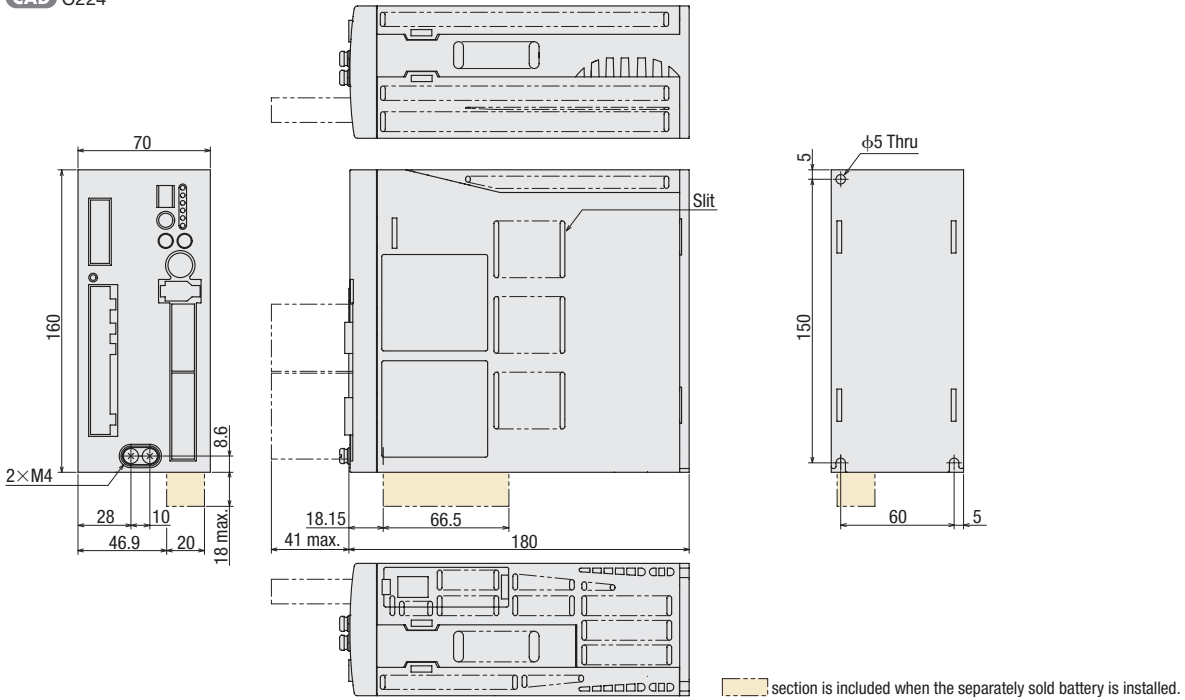

● Included

I/O Signal Connector (CN7)

Case: 54331-1361 (MOLEX)

Connector: 54306-3619 (MOLEX)

Connector for Regeneration Unit Input/Main Power Input Terminals (CN3)

Connector: 54928-0770 (MOLEX)

Connector for 24 VDC Power-Supply Input/Regeneration Unit Thermal Input/Electromagnetic Brake Terminals (CN1)

Connector: MC1,5/6-STF-3,5 (PHOENIX CONTACT Inc.)

Motor Connector (CN2)

Connector: 54928-0370 (MOLEX)

● Cables for Motor (Included), Cables for Encoder (Included), Cables for Electromagnetic Brake (Included)

● Cables for Motor

Cable Type	Length L (m)
Cable for Motor 1 m	1
Cable for Motor 2 m	2
Cable for Motor 3 m	3

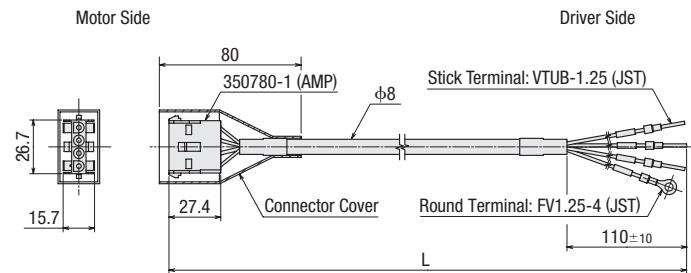

● Cables for Encoder

Cable Type	Length L (m)
Cable for Encoder 1 m	1
Cable for Encoder 2 m	2
Cable for Encoder 3 m	3

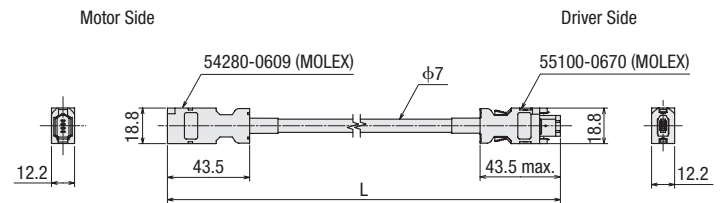

● Cables for Electromagnetic Brake  
(Electromagnetic brake type only)

Cable Type	Length L (m)
Cable for Electromagnetic Brake 1 m	1
Cable for Electromagnetic Brake 2 m	2
Cable for Electromagnetic Brake 3 m	3

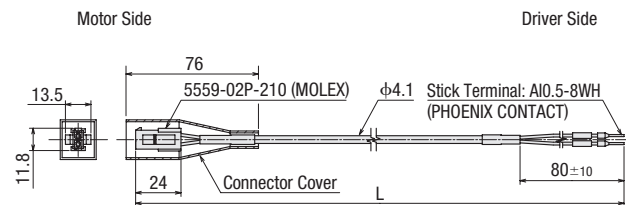



## Connection and Operation

### Names and Functions of Driver Parts (Common to position control, speed control, torque control, tension control modes)

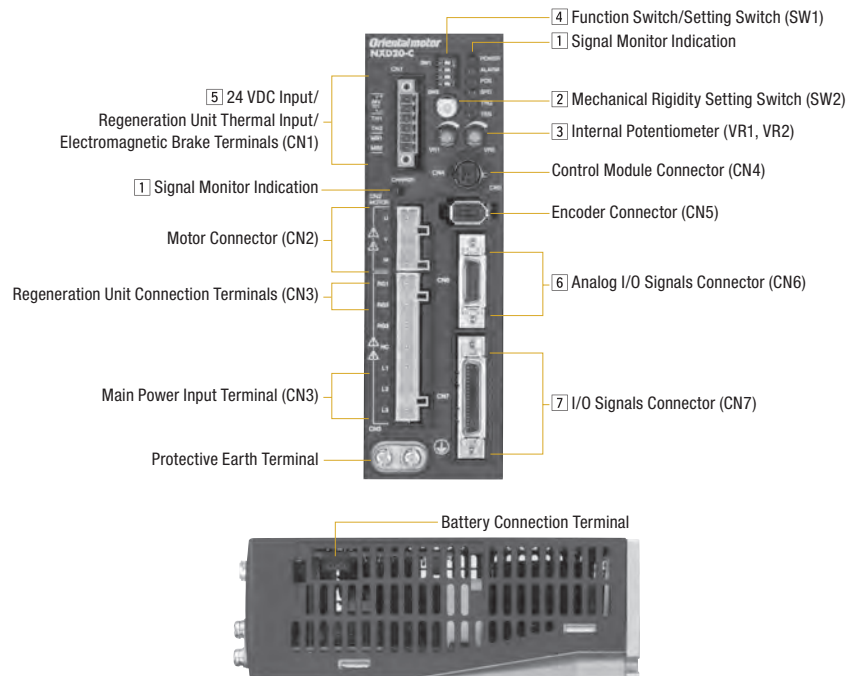

#### 1 Signal Monitor Indication

##### ◇ LED Indicator

Indication	Color	Function	Lighting Condition
POWER	Green	Power Supply Indication	When the main power supply or 24 VDC power supply is input
ALARM	Red	Alarm Indication	When a protective function is activated (blinking)
POS	Green	Control Mode Indication	For Position Control Mode
SPD	Green	Control Mode Indication	For Speed Control Mode
TRQ	Green	Control Mode Indication	For Torque Control Mode
TEN	Green	Control Mode Indication	For Tension Control Mode
CHARGE	Red	Power Supply Indication	When the main power supply is on

##### ◇ Alarm Contents

Blink Count	Function	Operating Condition
2	Overheat Protection	When the temperature inside the driver exceeds 85°C
	Motor Overheat Protection	When the motor temperature reaches 85°C
	Overload Protection	When a load exceeding the rated torque is applied for longer than the permissible time
3	Overspeed	When the motor output shaft speed exceeds 6000 r/min
	Command Pulse Error*	When a command pulse frequency that exceeds the maximum speed has been input with the motor output shaft speed
	Regeneration Unit Overheat	When the signal thermal protector for the regeneration unit has been activated
	Overvoltage Protection	When the primary voltage of the driver's inverter exceeds the upper limit value
4	Main Power Supply Error	When the main power supply has been cut off while an operation command is being input to the driver
	Undervoltage	When the primary voltage of the driver's inverter has fallen below the lower limit
5	Overflow*	When the positioning deviation has exceeded the overflow rotation amount (Initial value: 10 rotations)
7	Overcurrent Protection	An excessive current has flowed through the inverter power component inside the driver
	Position Range Error*	When the command position has exceeded the absolute control coordinates while the absolute functions are enabled (control coordinates: -2,147,483,648 to 2,147,483,647)
	Absolute Position Loss*	When the absolute position is lost while the absolute functions are enabled
	ABS Not Supported*	When the battery is connected while the absolute functions are disabled
8	No Battery*	When the battery is not connected or the battery cable is disconnected while the absolute functions are enabled
	Electronic Gear Setting Error	When the resolution set by the electronic gear is outside the range of the specifications
	Sensor Error during Operation	When an abnormality has occurred in a sensor while the motor is rotating
	Encoder Communication Error	When an abnormality has occurred in communications between the driver and encoder
	Sensor Error during Initialization	When the main power supply or control power supply was turned on before the motor cable was connected to the driver
	Rotor Rotation during Initialization	The main power supply or control power supply was turned on while the motor was rotating
	Encoder EEPROM Error	The saved data for the encoder communications circuit was damaged
Motor Combination Error	A motor that cannot be combined with the other components was connected	
9	EEPROM Error	A motor control parameter is damaged

\*An alarm generated when used in position control mode.

### 2] Mechanical Rigidity Setting Switch (SW2)

Indication	Switch Name	Function	
SW2	Mechanical Rigidity Setting Switch	Position Control Mode Speed Control Mode	Sets the mechanical rigidity and the corresponding gain adjustment level with automatic tuning and semi-auto tuning. Factory setting: "6"
		Torque Control Mode	Not used.
		Tension Control Mode	Sets the minimum speed in simple control mode. (Not used in high function mode I and high function mode II.) Factory setting: "6"

### 3] Internal Potentiometer (VR1, VR2)

Indication	Switch Name	Function	
VR1 VR2	Internal Potentiometer	Position Control Mode	VR1: Sets the vibration suppression frequency. VR2: Not used.
		Speed Control Mode	VR1: Sets the speed command value. VR2: Sets the acceleration/deceleration time.
		Torque Control Mode	VR1: Sets the torque command value. VR2: Sets the speed limit.
		Tension Control Mode	VR1: Sets the tension command value. VR2: Sets the speed limit.

### 4] Function Switch/Setting Switch (SW1)

Indication	Switch Name	Function
1	Control Mode Setting Switch	Selects the control mode. 1 "OFF" 2 "OFF" → Position Control Mode [Factory setting] 1 "ON" 2 "OFF" → Speed Control Mode
2		1 "OFF" 2 "ON" → Torque Control Mode 1 "ON" 2 "ON" → Tension Control Mode
3	Absolute System Setting Switch	Set when the accessory battery (sold separately) is installed to use the absolute functions. (This is effective in position control mode.) ON: Absolute Functions Enabled OFF: Absolute Functions Disabled [Factory setting]
4	Pulse Input Mode Select Switch	Switches the pulse input mode between 1-pulse input mode and 2-pulse input mode. ON: 1-Pulse Input Mode OFF: 2-Pulse Input Mode [Factory setting]

### 5] 24 VDC Input/Regeneration Unit Thermal/Electromagnetic Brake Terminals (CN1)

Indication	I/O	Terminal Name	Content
24V+	Input	24 VDC Power Input Terminal +	To separate the main power supply and control power supply, connect the power supplies here. The control power supply is not mandatory. When using an electromagnetic brake type motor, connect it as the power supply for the electromagnetic brake.
24V-		24 VDC Power Input Terminal -	
TH1		Regeneration Unit Thermal Input Terminal	Connect the <b>RGB100</b> or <b>RGB200</b> regeneration unit which are sold separately. When not connecting a regeneration unit, short these 2 terminals to each other.
TH2		Regeneration Unit Thermal Input Terminal	
MB1	Output	Electromagnetic Brake Terminal -	For an electromagnetic brake type motor, connect the electromagnetic brake line here.
MB2		Electromagnetic Brake Terminal +	

### 6] Analog I/O Signals Connector (CN6)

Indication	I/O	Pin Number	Code	Signal Name	
CN6	Input	1	V-REF	Analog Speed (Command/limit) Input	
	GND	2	SG	Signal Ground	
	Output	3	P-VREF	Reference Output Voltage for Analog Speed (Command/limit) Input	
		4	P-TREF	Analog Torque (Command/limit) Input	
	Input	5	T-REF	Analog Torque (Command/limit) Input	
	GND	6	SG	Signal Ground	
	Output	7	V-MON	Analog Speed Monitor Output	
	GND	8	SG	Signal Ground	
	Output	9	T-MON	Analog Torque Monitor Output	
	GND	10	SG	Signal Ground	
	-	-	11	-	-
			12		
			13		
			14		
			15		
			16		
			17		
			18		
			19		
			20		

### 7] I/O Signals Connector (CN7)

- Position control mode → Page 29
- Speed control mode → Page 29
- Torque control mode → Page 30
- Tension control mode → Page 30

● Connection Diagram (Common to position control, speed control, torque control, and tension control modes)

◇ Connections with Peripheral Equipment

● For **NX620AC**-◇

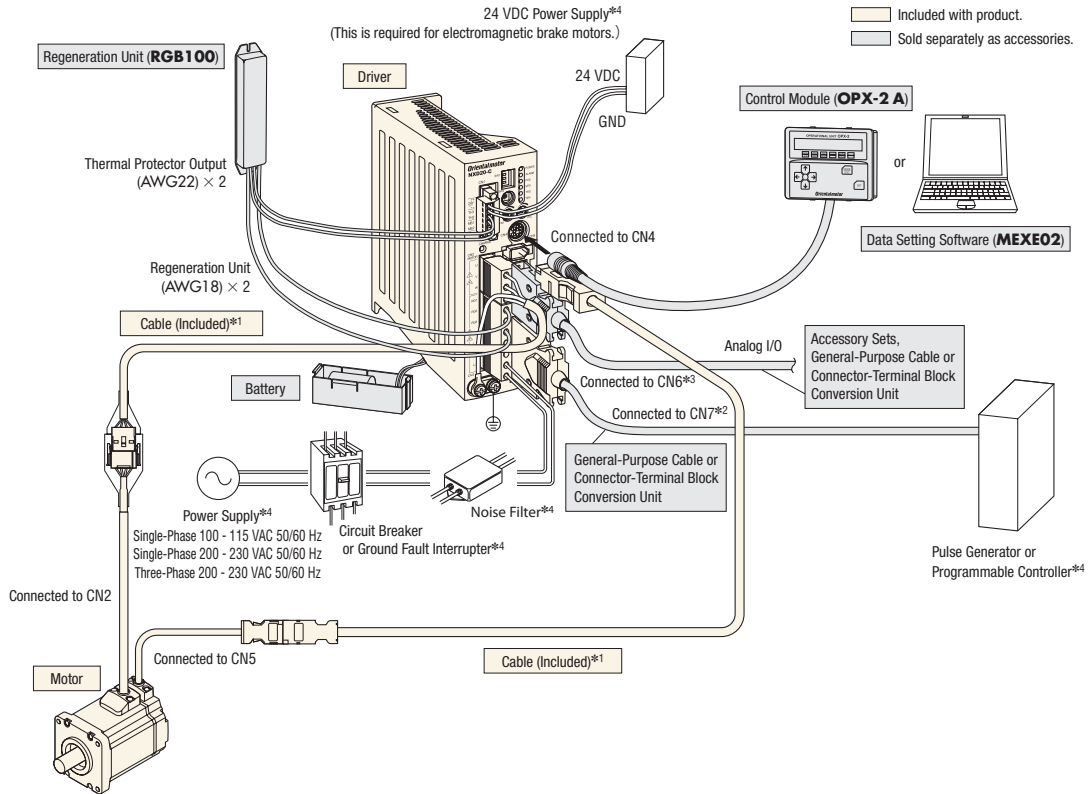

- \*1 1 m, 2 m or 3 m cables are included with the product. If you need cables longer than 3 m or flexible cables, select appropriate cables from the accessories (sold separately).
- \*2 The control I/O connector (CN7) is included with the product, but you can also purchase an accessory general-purpose cable or connector – terminal block conversion unit (sold separately). Choose one or the other.
- \*3 The Analog I/O Signals Connector (CN6) is not included with the product. You can also purchase an accessory set, general-purpose cable or connector – terminal block conversion unit (sold separately). Choose one that suits your needs.
- \*4 Not supplied.

◇ Connecting the Main Power Supply

Prepare the following cable for the power supply lines.

Single-Phase 100-115 VAC: Three-Core Cable [AWG16 to 14 (1.25 to 2.0 mm<sup>2</sup>)]

Single-Phase 200-230 VAC: Three-Core Cable [AWG16 to 14 (1.25 to 2.0 mm<sup>2</sup>)]

Three-Phase 200-230 VAC: Four-Core Cable [AWG16 to 14 (1.25 to 2.0 mm<sup>2</sup>)]

● Single-Phase 100-115 VAC

● Single-Phase 200-230 VAC

● Three-Phase 200-230 VAC

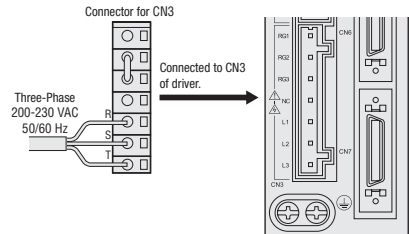
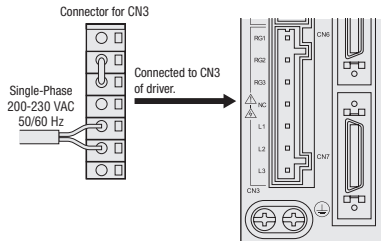
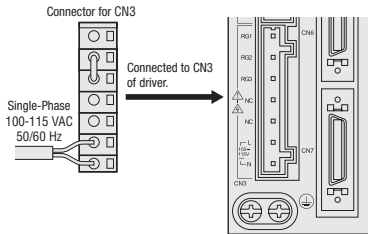

◇ Connecting the Control Power Supply

To separate the main power supply and control power supply, connect 24 VDC. The control power supply is not mandatory.

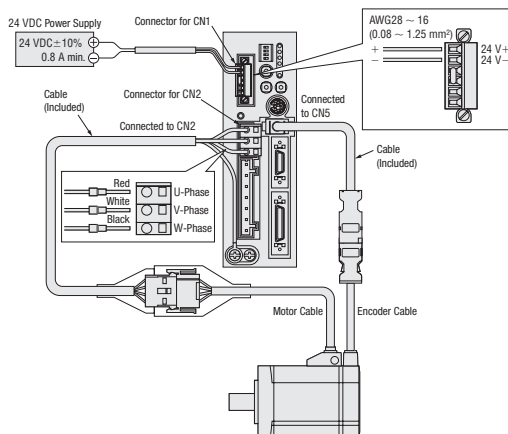

◇ Connecting the Electromagnetic Brake

Connect 24 VDC.

The main power supply and control power supply are separated in this case too.

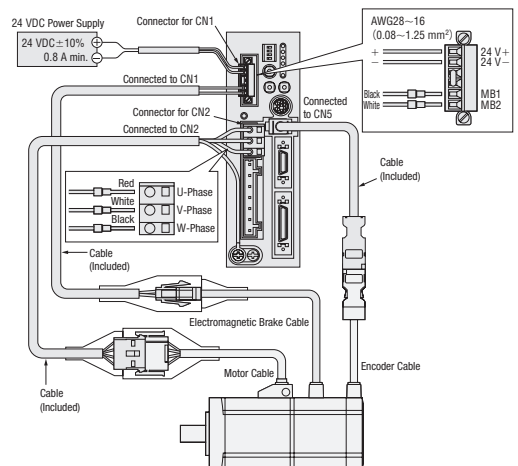

◇ Connection to Programmable Controller

● Connection Diagram for Connection with Current Sink Output Circuit

When pulse input is performed using the line driver mode

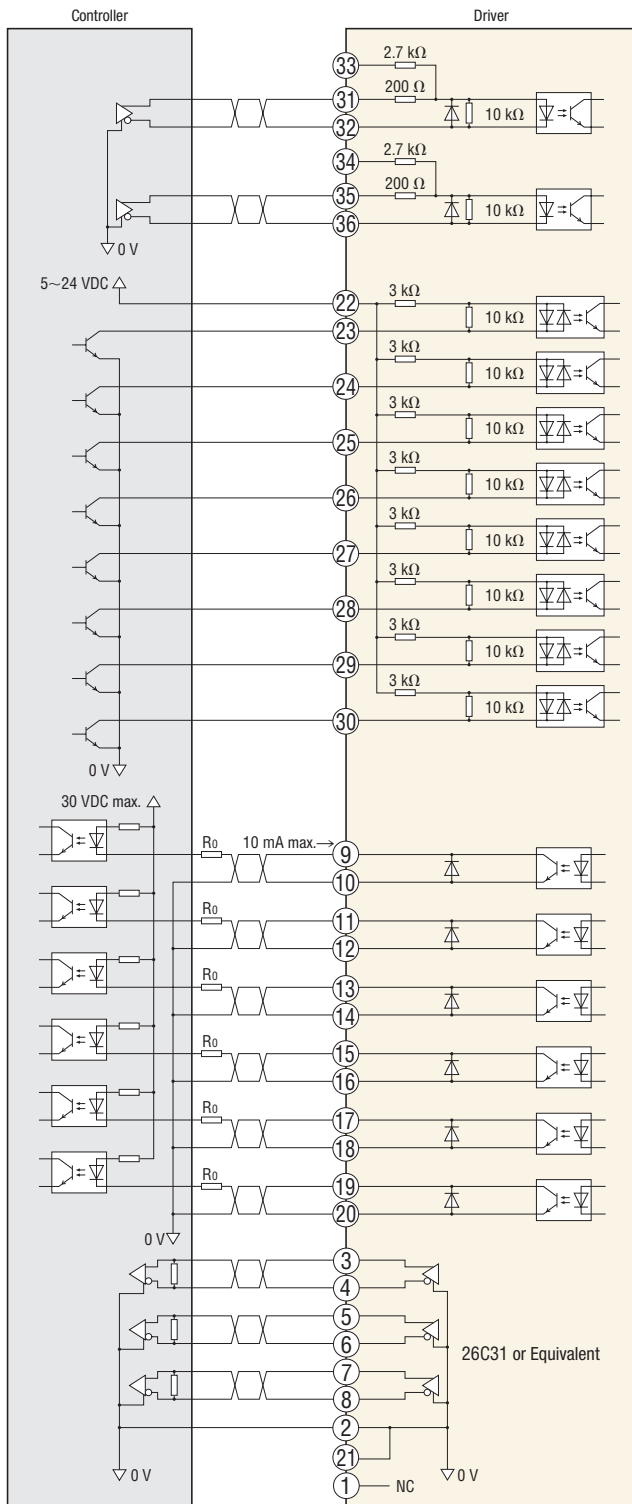

When the input voltage is 5 VDC

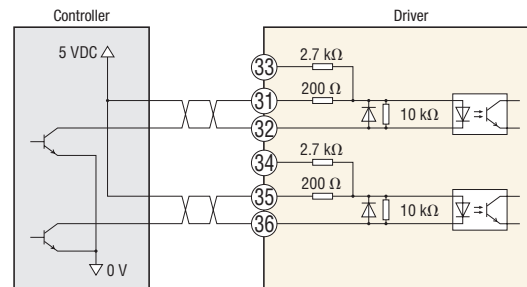

When the input voltage is 24 VDC

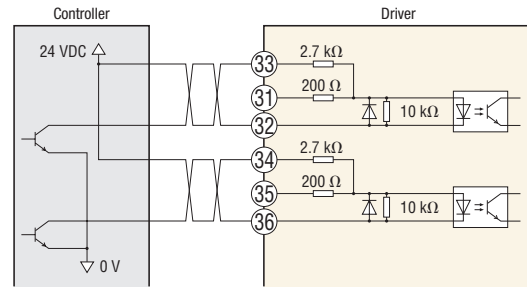

Note

- Use output signals of 30 VDC max. When the current value exceeds 10 mA, connect the external resistor  $R_o$ .
- Connect a terminating resistor of 100  $\Omega$  min. between the line receiver inputs.
- For the control I/O signal lines (CN7), use a multi-core shielded twisted-pair wire [AWG28 to 26 (0.08 to 0.14 mm<sup>2</sup>)] and keep the wiring length as short as possible (no more than 2 m).
- Note that as the length of the pulse line increases, the maximum frequency decreases.
- Provide a distance of 200 mm min. between the control I/O signal lines and power lines (power supply lines, motor lines and other large-current circuits).

### ◇ Connection to Programmable Controller

#### ● Connection Diagram for Connection with Current Source Output Circuit

When pulse input is performed using the line driver mode

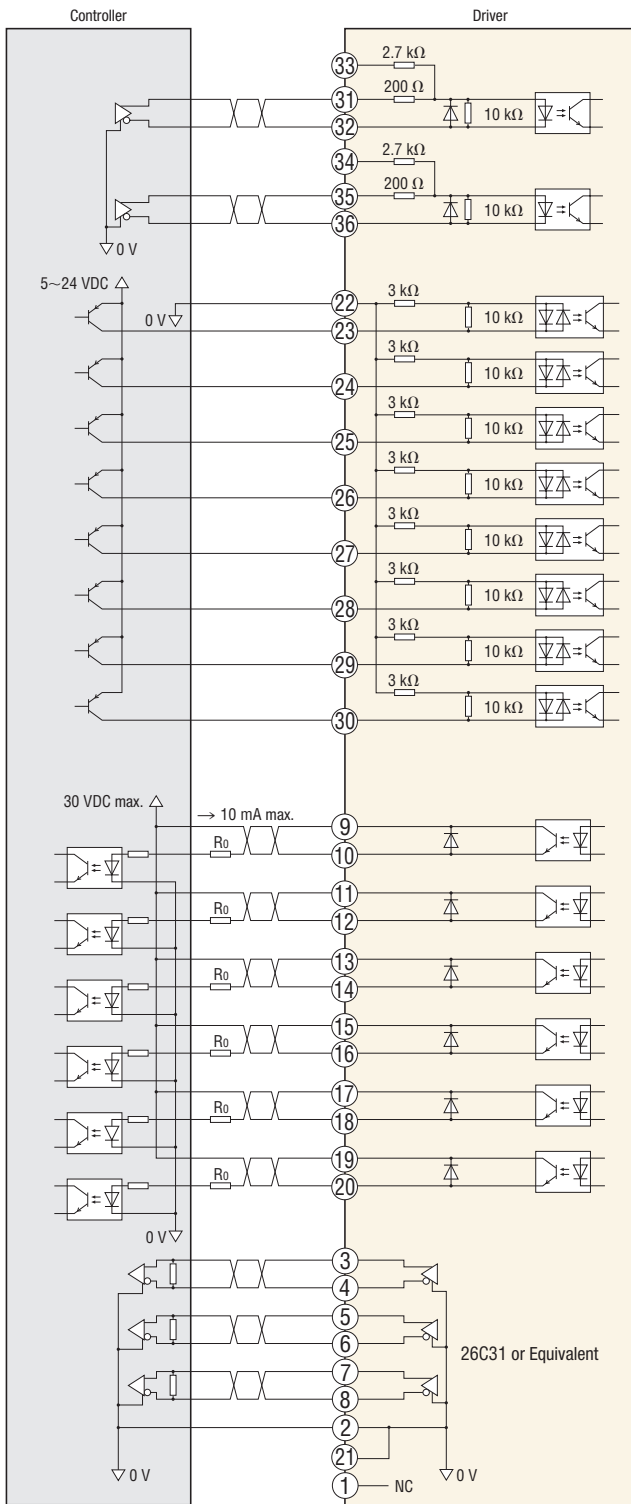

When the input voltage is 5 VDC

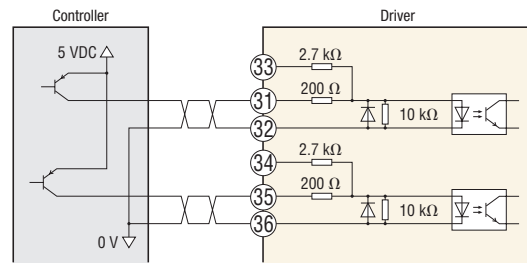

When the input voltage is 24 VDC

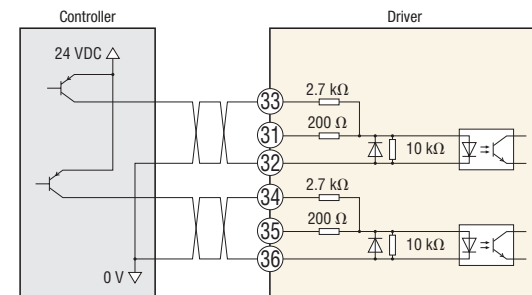

#### Note

- Use output signals of 30 VDC max. When the current value exceeds 10 mA, connect the external resistor  $R_0$ .
- Connect a terminating resistor of 100  $\Omega$  min. between the line receiver inputs.
- For the control I/O signal lines (CN7), use a multi-core shielded twisted-pair wire [AWG28 to 26 (0.08 to 0.14 mm<sup>2</sup>)] and keep the wiring length as short as possible (no more than 2 m).
- Note that as the length of the pulse line increases, the maximum frequency decreases.
- Provide a distance of 200 mm min. between the control I/O signal lines and power lines (power supply lines, motor lines and other large-current circuits).

### ◇ Analog I/O Connection

When using analog I/O, the accessory set is required (sold separately).

Accessory Set → Page 43

#### ● Input Circuit

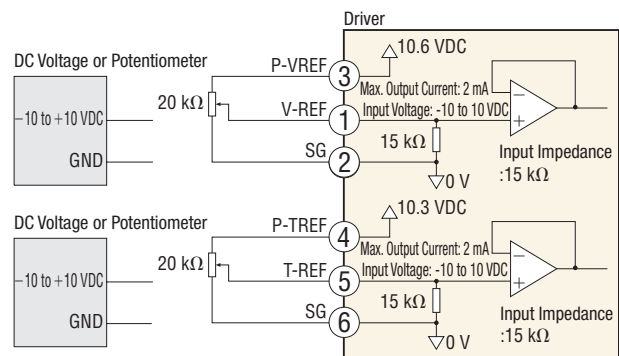

#### ● Output Circuit

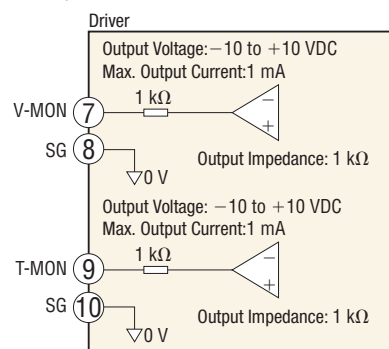

## Description of Position Control Mode I/O Signals

### ● Position Control Mode

In position control mode, the following functions are enabled.

- External positioning operation using pulse input
- Torque limiting
- Absolute system
- Current position output
- Tuning
- Damping control

### ● I/O Signals (CN7, 36 pins)

Indication	I/O	Pin Number	Code	Signal Name
	—	1	—	—
	GND	2	GND	Ground Connection
		3	ASG+	A-Phase Pulse Line Driver Output
		4	ASG—	A-Phase Pulse Line Driver Output
		5	BSG+	B-Phase Pulse Line Driver Output
		6	BSG—	B-Phase Pulse Line Driver Output
		7	ZSG1+	Z-Phase Pulse Line Driver Output
		8	ZSG1—	Z-Phase Pulse Line Driver Output
		9	ALM+	Alarm Output
		10	ALM—	Alarm Output
		11	WNG+/MOVE+*/MBC+*	Warning Output/ Motor Moving Output*/ Electromagnetic Brake Control Signal Output*
		12	WNG-/MOVE—*/MBC—*	Warning Output/ Motor Moving Output*/ Electromagnetic Brake Control Signal Output*
	Output	13	END+	Positioning Completion Output
		14	END—	Positioning Completion Output
		15	READY+/AL0+*/P-OUTR+	Operation Ready Output/ Alarm Code Output Bit 0*/ Position Data Output Ready Output
		16	READY-/AL0—*/P-OUTR—	Operation Ready Output/ Alarm Code Output Bit 0*/ Position Data Output Ready Output
		17	TLC+/AL1+*/P-OUT0+	Torque Limiting Output/Alarm Code Output Bit 1*/Position Data Output Bit 0
		18	TLC-/AL1—*/P-OUT0—	Torque Limiting Output/Alarm Code Output Bit 1*/Position Data Output Bit 0
CN7		19	ZSG2+/NEAR+*/AL2+*/P-OUT1+	Z-Phase Pulse Open Collector Output/Positioning Near Output*/Alarm Code Output Bit 2*/Position Data Output Bit 1
		20	ZSG2-/NEAR—*/AL2—*/P-OUT1—	Z-Phase Pulse Open Collector Output/Positioning Near Output*/Alarm Code Output Bit 2*/Position Data Output Bit 1
	GND	21	GND	Ground Connection
		22	IN-COM	Input Common
		23	S-ON	Position Holding Input by Servo Control
		24	CLR/ALM-RST/P-CK	Deviation Clear Input/Alarm Reset Input/Position Data Transmission Clock Input
		25	P-REQ	Position Data Request Input
		26	TL	Torque Limit Enable Input
		27	M0	Data Selection Input
		28	M1	Data Selection Input
		29	P-PRESET	Position Preset Input
		30	FREE	Shaft Free Input
		31	CW+/PLS+	CW Pulse Input/Pulse Input
		32	CW-/PLS—	CW Pulse Input/Pulse Input
		33	CW+24 V/PLS+24 V	CW Pulse Input/Pulse Input for 24 VDC
		34	CCW+24 V/DIR+24 V	CCW Pulse Input/Rotation Direction Input for 24 VDC
		35	CCW+/DIR+	CCW Pulse Input/Rotation Direction Input
		36	CCW-/DIR—	CCW Pulse Input/Rotation Direction Input

\*Enabled when the settings are changed with the separately-sold control module (OPX-2A) or data setting software (MEXE02).

## Description of Speed Control Mode I/O Signals

### ● Speed Control Mode

In speed control mode, the following functions are enabled.

- Speed control operation
- Torque limiting
- Tuning

### ● I/O Signals (CN7, 36 pins)

Indication	I/O	Pin Number	Code	Signal Name
	—	1	—	—
	GND	2	GND	Ground Connection
		3	ASG+	A-Phase Pulse Line Driver Output
		4	ASG—	A-Phase Pulse Line Driver Output
		5	BSG+	B-Phase Pulse Line Driver Output
		6	BSG—	B-Phase Pulse Line Driver Output
		7	ZSG1+	Z-Phase Pulse Line Driver Output
		8	ZSG1—	Z-Phase Pulse Line Driver Output
		9	ALM+	Alarm Output
		10	ALM—	Alarm Output
		11	WNG+/MOVE+*/MBC+*	Warning Output/ Motor Moving Output*/ Electromagnetic Brake Control Signal Output*
		12	WNG-/MOVE—*/MBC—*	Warning Output/ Motor Moving Output*/ Electromagnetic Brake Control Signal Output*
	Output	13	VA+	Speed Attainment Output
		14	VA—	Speed Attainment Output
		15	READY+/AL0+*	Operation Ready Output/ Alarm Code Output Bit 0*
		16	READY-/AL0—*	Operation Ready Output/ Alarm Code Output Bit 0*
		17	TLC+/AL1+*	Torque Limiting Output/Alarm Code Output Bit 1*
		18	TLC-/AL1—*	Torque Limiting Output/Alarm Code Output Bit 1*
		19	ZSG2+/ZV+*/AL2+*	Z-Phase Pulse Open Collector Output/Motor Zero Speed Output*/Alarm Code Output Bit 2*
		20	ZSG2-/ZV—*/AL2—*	Z-Phase Pulse Open Collector Output/Motor Zero Speed Output*/Alarm Code Output Bit 2*
	GND	21	GND	Ground Connection
		22	IN-COM	Input Common
		23	S-ON	Position Holding Input by Servo Control
		24	ALM-RST	Alarm Reset Input
		25	BRAKE	Instantaneous Stop Input
		26	TL	Torque Limit Enable Input
		27	M0	Data Selection Input
		28	M1	Data Selection Input
		29	M2	Data Selection Input
		30	FREE	Shaft Free Input
		31	CW+	CW Input
		32	CW—	CW Input
		33	CW+24 V	CW Input for 24 VDC
		34	CCW+24 V	CCW Input for 24 VDC
		35	CCW+	CCW Input
		36	CCW—	CCW Input

\*Enabled when the settings are changed with the separately-sold control module (OPX-2A) or data setting software (MEXE02).

## Description of Torque Control Mode I/O Signals

### Torque Control Mode

In torque control mode, the following functions are enabled.

- Torque control operation
- Speed limit

### I/O Signals (CN7, 36 pins)

Indication	I/O	Pin Number	Code	Signal Name
		1	—	—
	GND	2	GND	Ground Connection
Output		3	ASG+	A-Phase Pulse Line Driver Output
		4	ASG—	
		5	BSG+	B-Phase Pulse Line Driver Output
		6	BSG—	
		7	ZSG1+	Z-Phase Pulse Line Driver Output
		8	ZSG1—	
		9	ALM+	Alarm Output
		10	ALM—	
		11	WNG+/MOVE+*/MBC+*	Warning Output/ Motor Moving Output*/ Electromagnetic Brake Control Signal Output*
		12	WNG—/MOVE—*/MBC—*	
		13	—	—
		14	—	—
		15	READY+/ALO+*	Operation Ready Output/ Alarm Code Output Bit 0*
		16	READY—/ALO—*	
		17	VLC+/AL1+*	Speed Limit Output/Alarm Code Output Bit 1*
		18	VLC—/AL1—*	
		19	ZSG2+/ZV+*/AL2+*	Z-Phase Pulse Open Collector Output/Motor Zero Speed Output*/Alarm Code Output Bit 2*
		20	ZSG2—/ZV—*/AL2—*	
	GND	21	GND	Ground Connection
Input		22	IN-COM	Input Common
		23	—	—
		24	ALM-RST	Alarm Reset Input
		25	—	—
		26	—	—
		27	M0	Data Selection Input
		28	M1	
		29	M2	
		30	FREE	Shaft Free Input
		31	CW+	CW Input
		32	CW—	
		33	CW+24 V	CW Input for 24 VDC
		34	CCW+24 V	CCW Input for 24 VDC
		35	CCW+	CCW Input
		36	CCW—	

\*Enabled when the settings are changed with the separately-sold control module (**OPX-2A**) or data setting software (**MEXE02**).

## Description of Tension Control Mode I/O Signals

### Tension Control Mode

When winding a roll of film, paper or the like, the diameter of the material is different at the start of the winding and at the end of the winding. Accordingly, control is required to vary the torque with the diameter in order to hold the tension constant. In tension control mode, such control is enabled.

In tension control mode, there are 3 operating modes. The operating mode can be selected and the operating data is set with the separately-sold control module (**OPX-2A**) or data setting software (**MEXE02**).

Operating Mode	Content
Simple Mode	The tension is controlled to be constant when the feed speed is constant such as during winding operation. The motor speed and the torque are inversely proportional.
High Function Mode I	The current winding (winding out) diameter is automatically calculated based on the initial diameter, the material thickness, and the final diameter. The tension is controlled to stay constant regardless of the operating speed.
High Function Mode II	In addition to the contents of high function I, the load inertia is calculated within the driver from the material inertia and the core inertia. The tension is controlled to stay constant even during acceleration/deceleration.

Setting Item	Operating Mode		
	Simple Mode	High Function Mode I	High Function Mode II
Tension Command Value	○	○	○
Material Thickness	—	○	○
Initial Diameter	—	○	○
Final Diameter	—	○	○
Material Inertia	—	—	○
Core Inertia	—	—	○
Taper Setting	—	○	○
Speed Limit	○	○	○

### I/O Signals (CN7, 36 pins)

Indication	I/O	Pin Number	Code	Signal Name
		1	—	—
	GND	2	GND	Ground Connection
Output		3	ASG+	A-Phase Pulse Line Driver Output
		4	ASG—	
		5	BSG+	B-Phase Pulse Line Driver Output
		6	BSG—	
		7	ZSG1+	Z-Phase Pulse Line Driver Output
		8	ZSG1—	
		9	ALM+	Alarm Output
		10	ALM—	
		11	WNG+/MOVE+*/MBC+*	Warning Output/ Motor Moving Output*/ Electromagnetic Brake Control Signal Output*
		12	WNG—/MOVE—*/MBC—*	
		13	—	—
		14	—	—
		15	READY+/ALO+*	Operation Ready Output/ Alarm Code Output Bit 0*
		16	READY—/ALO—*	
		17	VLC+/AL1+*	Speed Limit Output/Alarm Code Output Bit 1*
		18	VLC—/AL1—*	
		19	ZSG2+/ZV+*/AL2+*	Z-Phase Pulse Open Collector Output/Motor Zero Speed Output*/Alarm Code Output Bit 2*
		20	ZSG2—/ZV—*/AL2—*	
	GND	21	GND	Ground Connection
Input		22	IN-COM	Input Common
		23	—	—
		24	ALM-RST	Alarm Reset Input
		25	—	—
		26	W-RESET	Winding Diameter Reset Input
		27	M0	Data Selection Input
		28	M1	
		29	M2	
		30	FREE	Shaft Free Input
		31	CW+	CW Input
		32	CW—	
		33	CW+24 V	CW Input for 24 VDC
		34	CCW+24 V	CCW Input for 24 VDC
		35	CCW+	CCW Input
		36	CCW—	

\*Enabled when the settings are changed with the separately-sold control module (**OPX-2A**) or data setting software (**MEXE02**).



## Motor and Driver Combinations

Product names for motor and driver combinations are shown below.

### Standard Type

Power-Supply Input	Output Power	Product Name	Motor Product Name	Driver Product Name
Single-Phase 100-115 VAC	50 W	<b>NX45AA</b> -◇	NXM45A	NXD20-A
	100 W	<b>NX410AA</b> -◇	NXM410A	
	200 W	<b>NX620AA</b> -◇	NXM620A	
Single-Phase/ Three-Phase 200-230 VAC	50 W	<b>NX45AC</b> -◇	NXM45A	NXD20-C
	100 W	<b>NX410AC</b> -◇	NXM410A	
	200 W	<b>NX620AC</b> -◇	NXM620A	
Three-Phase 200-230 VAC	400 W	<b>NX640AS</b> -◇	NXM640A	NXD75-S
	750 W	<b>NX975AS</b> -◇	NXM975A	

### PS Geared Type

Power-Supply Input	Output Power	Product Name	Motor Product Name	Driver Product Name
Single-Phase 100-115 VAC	50 W	<b>NX65AA-PS5</b> -◇	NXM65A-PS5	NXD20-A
		<b>NX65AA-PS10</b> -◇	NXM65A-PS10	
		<b>NX65AA-PS25</b> -◇	NXM65A-PS25	
	100 W	<b>NX610AA-PS5</b> -◇	NXM610A-PS5	
		<b>NX610AA-PS10</b> -◇	NXM610A-PS10	
		<b>NX610AA-PS25</b> -◇	NXM610A-PS25	
	200 W	<b>NX920AA-PS5</b> -◇	NXM920A-PS5	
		<b>NX920AA-PS10</b> -◇	NXM920A-PS10	
		<b>NX920AA-PS25</b> -◇	NXM920A-PS25	
Single-Phase/ Three-Phase 200-230 VAC	50 W	<b>NX65AC-PS5</b> -◇	NXM65A-PS5	NXD20-C
		<b>NX65AC-PS10</b> -◇	NXM65A-PS10	
		<b>NX65AC-PS25</b> -◇	NXM65A-PS25	
	100 W	<b>NX610AC-PS5</b> -◇	NXM610A-PS5	
		<b>NX610AC-PS10</b> -◇	NXM610A-PS10	
		<b>NX610AC-PS25</b> -◇	NXM610A-PS25	
	200 W	<b>NX920AC-PS5</b> -◇	NXM920A-PS5	
		<b>NX920AC-PS10</b> -◇	NXM920A-PS10	
		<b>NX920AC-PS25</b> -◇	NXM920A-PS25	
Three-Phase 200-230 VAC	400 W	<b>NX940AS-PS5</b> -◇	NXM940A-PS5	NXD75-S
		<b>NX940AS-PS10</b> -◇	NXM940A-PS10	
		<b>NX940AS-PS25</b> -◇	NXM940A-PS25	

### PJ Geared Type

Power-Supply Input	Output Power	Product Name	Motor Product Name	Driver Product Name
Single-Phase 100-115 VAC	100 W	<b>NX810AA-J5</b> -◇	NXM810A-J5	NXD20-A
		<b>NX810AA-J10</b> -◇	NXM810A-J10	
		<b>NX810AA-J25</b> -◇	NXM810A-J25	
	200 W	<b>NX820AA-J5</b> -◇	NXM820A-J5	
		<b>NX820AA-J10</b> -◇	NXM820A-J10	
		<b>NX820AA-J25</b> -◇	NXM820A-J25	
Single-Phase/ Three-Phase 200-230 VAC	100 W	<b>NX810AC-J5</b> -◇	NXM810A-J5	NXD20-C
		<b>NX810AC-J10</b> -◇	NXM810A-J10	
		<b>NX810AC-J25</b> -◇	NXM810A-J25	
	200 W	<b>NX820AC-J5</b> -◇	NXM820A-J5	
		<b>NX820AC-J10</b> -◇	NXM820A-J10	
		<b>NX820AC-J25</b> -◇	NXM820A-J25	
Three-Phase 200-230 VAC	400 W	<b>NX1040AS-J5</b> -◇	NXM1040A-J5	NXD75-S
		<b>NX1040AS-J10</b> -◇	NXM1040A-J10	
		<b>NX1040AS-J25</b> -◇	NXM1040A-J25	
	750 W	<b>NX1075AS-J5</b> -◇	NXM1075A-J5	
		<b>NX1075AS-J10</b> -◇	NXM1075A-J10	
		<b>NX1075AS-J25</b> -◇	NXM1075A-J25	

● A number indicating the desired length of **1** (1 m), **2** (2 m) or **3** (3 m) for the cables included with the product is entered where the box ◇ is located within the product name.

### Standard Type with Electromagnetic Brake

Power-Supply Input	Output Power	Product Name	Motor Product Name	Driver Product Name
Single-Phase 100-115 VAC	50 W	<b>NX45MA</b> -◇	NXM45M	NXD20-A
	100 W	<b>NX410MA</b> -◇	NXM410M	
	200 W	<b>NX620MA</b> -◇	NXM620M	
Single-Phase/ Three-Phase 200-230 VAC	50 W	<b>NX45MC</b> -◇	NXM45M	NXD20-C
	100 W	<b>NX410MC</b> -◇	NXM410M	
	200 W	<b>NX620MC</b> -◇	NXM620M	
Three-Phase 200-230 VAC	400 W	<b>NX640MS</b> -◇	NXM640M	NXD75-S
	750 W	<b>NX975MS</b> -◇	NXM975M	

### PS Geared Type with Electromagnetic Brake

Power-Supply Input	Output Power	Product Name	Motor Product Name	Driver Product Name
Single-Phase 100-115 VAC	50 W	<b>NX65MA-PS5</b> -◇	NXM65M-PS5	NXD20-A
		<b>NX65MA-PS10</b> -◇	NXM65M-PS10	
		<b>NX65MA-PS25</b> -◇	NXM65M-PS25	
	100 W	<b>NX610MA-PS5</b> -◇	NXM610M-PS5	
		<b>NX610MA-PS10</b> -◇	NXM610M-PS10	
		<b>NX610MA-PS25</b> -◇	NXM610M-PS25	
	200 W	<b>NX920MA-PS5</b> -◇	NXM920M-PS5	
		<b>NX920MA-PS10</b> -◇	NXM920M-PS10	
		<b>NX920MA-PS25</b> -◇	NXM920M-PS25	
Single-Phase/ Three-Phase 200-230 VAC	50 W	<b>NX65MC-PS5</b> -◇	NXM65M-PS5	NXD20-C
		<b>NX65MC-PS10</b> -◇	NXM65M-PS10	
		<b>NX65MC-PS25</b> -◇	NXM65M-PS25	
	100 W	<b>NX610MC-PS5</b> -◇	NXM610M-PS5	
		<b>NX610MC-PS10</b> -◇	NXM610M-PS10	
		<b>NX610MC-PS25</b> -◇	NXM610M-PS25	
	200 W	<b>NX920MC-PS5</b> -◇	NXM920M-PS5	
		<b>NX920MC-PS10</b> -◇	NXM920M-PS10	
		<b>NX920MC-PS25</b> -◇	NXM920M-PS25	
Three-Phase 200-230 VAC	400 W	<b>NX940MS-PS5</b> -◇	NXM940M-PS5	NXD75-S
		<b>NX940MS-PS10</b> -◇	NXM940M-PS10	
		<b>NX940MS-PS25</b> -◇	NXM940M-PS25	

### PJ Geared Type with Electromagnetic Brake

Power-Supply Input	Output Power	Product Name	Motor Product Name	Driver Product Name
Single-Phase 100-115 VAC	100 W	<b>NX810MA-J5</b> -◇	NXM810M-J5	NXD20-A
		<b>NX810MA-J10</b> -◇	NXM810M-J10	
		<b>NX810MA-J25</b> -◇	NXM810M-J25	
	200 W	<b>NX820MA-J5</b> -◇	NXM820M-J5	
		<b>NX820MA-J10</b> -◇	NXM820M-J10	
		<b>NX820MA-J25</b> -◇	NXM820M-J25	
Single-Phase/ Three-Phase 200-230 VAC	100 W	<b>NX810MC-J5</b> -◇	NXM810M-J5	NXD20-C
		<b>NX810MC-J10</b> -◇	NXM810M-J10	
		<b>NX810MC-J25</b> -◇	NXM810M-J25	
	200 W	<b>NX820MC-J5</b> -◇	NXM820M-J5	
		<b>NX820MC-J10</b> -◇	NXM820M-J10	
		<b>NX820MC-J25</b> -◇	NXM820M-J25	
Three-Phase 200-230 VAC	400 W	<b>NX1040MS-J5</b> -◇	NXM1040M-J5	NXD75-S
		<b>NX1040MS-J10</b> -◇	NXM1040M-J10	
		<b>NX1040MS-J25</b> -◇	NXM1040M-J25	
	750 W	<b>NX1075MS-J5</b> -◇	NXM1075M-J5	
		<b>NX1075MS-J10</b> -◇	NXM1075M-J10	
		<b>NX1075MS-J25</b> -◇	NXM1075M-J25	

## Extended Functions

With the separately-sold control module (**OPX-2A**) or data editing software (**MEXE02**), the parameters, operating data, resolution, etc. can be set to suit your equipment. The settings that can be set with extended functions depend on the mode used.



Control Module (**OPX-2A**)

→ Page 41

Data setting software (**MEXE02**)

→ Page 41

### Position Control Mode

#### ◇ Operating Data

Item	Content
Torque Limiting	Sets the torque limiting value.
Vibration Suppression Frequency	Sets the damping control frequency.

#### ◇ System Parameters

Item	Content
Electronic Gear A	Sets the electronic gear denominator.
Electronic Gear B	Sets the electronic gear numerator.
Encoder Output Electronic Gear A	Sets the electronic gear denominator for encoder output.
Encoder Output Electronic Gear B	Sets the electronic gear numerator for encoder output.
Pulse Input Mode	Selects the pulse input mode.
Operation after Absolute Position Loss Alarm Reset	Selects the operation mode for after the absolute position loss alarm is reset.
Analog Input Signal	Enables/disables analog input signals.
Motor Rotation Direction	Selects the motor rotation direction.
Control Module Initial Display	Selects the initial display for when communications start between the control module and the driver. If an item is selected that is not displayed in position control mode, the monitor mode top screen becomes the initial display.

#### ◇ Application Parameters

Item	Content
Gain Tuning Mode Selection	Selects the gain tuning mode.
Load Inertia Ratio	Sets the ratio of the load inertia and motor inertia.
Mechanical Rigidity Setting	Selects the rigidity of automatic tuning, semi-auto tuning, and manual tuning.
Position Loop Gain	Sets the position loop gain. The larger this value, the higher the responsiveness.
Speed Loop Gain	Sets the speed loop gain. The larger this value, the higher the responsiveness.
Speed Loop Integration Time Constant	Sets the speed loop integration time constant. The smaller this value, the higher the responsiveness.
Speed Feed-Forward Ratio	Sets the speed feed-forward ratio. The larger this value, the higher the responsiveness.
S-ON Signal Logic	Switches the S-ON input logic.
Output Signal Selection 1	Selects the output signal.
Output Signal Selection 2	Selects the output signal.
Positioning Completion Output Range	Sets the END output conditions.
Positioning Near Output Range	Sets the NEAR output conditions.
MOVE Signal Min. ON Time	Sets the min. duration that MOVE output is ON.
Preset Value	Sets the preset position.
Alarm Code Output	Enables/disables alarm code output.
Analog Torque Limit Gain	Sets the torque limiting for 1 V of analog input voltage.
Analog Torque Limiting Offset Voltage	Sets the offset voltage for analog torque limiting input.
Analog Input Signal Automatic Offset	Enables/disables analog input signal automatic offset.
Analog Speed Monitor Max. Value	Sets the max. value for the analog speed monitor. The slope for the analog speed monitor output is decided.
Analog Speed Monitor Max. Voltage	Sets the monitor output voltage for the max. value of the analog speed monitor.
Analog Speed Monitor Offset Voltage	Sets the offset voltage for the analog speed monitor.
Analog Torque Monitor Max. Value	Sets the max. value for the analog torque monitor. The slope for the analog torque monitor output is decided.
Analog Torque Monitor Max. Voltage	Sets the monitor output voltage for the max. value of the analog torque monitor.
Analog Torque Monitor Offset Voltage	Sets the offset voltage for analog torque monitor.
Mechanical Rigidity Setting Switch	Enables/disables the driver's mechanical rigidity setting switch (SW2).
Command Filter	Sets the command filter time constant.
Damping Control	Enables/disables damping control.
Overflow Alarm	Sets the condition for an overflow alarm with a motor shaft rotation amount.
Overflow Warning	Sets the condition for an overflow warning with a motor shaft rotation amount.
Overvoltage Warning	Sets the voltage at which an overvoltage warning is issued.
Undervoltage Warning	Sets the voltage at which an undervoltage warning is issued.
Overheat Warning	Sets the temperature at which an overheat warning is issued.
Overload Warning	Sets the condition for which an overload warning is issued.
Overspeed Warning	Sets the speed at which an overspeed warning is issued.
Gear Ratio for Speed Monitor	Sets the geared motor gear ratio for speed monitor.

## ● Speed Control Mode

### ◇ Operating Data

Item	Content
Operating Speed	Sets the operating speed.
Torque Limiting	Sets the torque limiting value.
Acceleration Time	Sets the acceleration time per 1000 r/min.
Deceleration Time	Sets the deceleration time per 1000 r/min.

### ◇ System Parameters

Item	Content
Encoder Output Electronic Gear A	Sets the electronic gear denominator for encoder output.
Encoder Output Electronic Gear B	Sets the electronic gear numerator for encoder output.
Operation Selection during Speed Control Mode Stop	Sets the operation during speed control mode is stopped.
Analog Input Signal	Enables/disables analog input signals.
Motor Rotation Direction	Selects the motor rotation direction.
Control Module Initial Display	Selects the initial display for when communications start between the control module and the driver. If an item is selected that is not displayed in speed control mode, the monitor mode top screen becomes the initial display.

### ◇ Application Parameters

Item	Content
Gain Tuning Mode Selection	Selects the gain tuning mode.
Load Inertia Ratio	Sets the ratio of the load inertia and motor inertia.
Mechanical Rigidity Setting	Selects the rigidity of automatic tuning, semi-auto tuning, and manual tuning.
Position Loop Gain*	Sets the position loop gain. The larger this value, the higher the responsiveness.
Speed Loop Gain*	Sets the speed loop gain. The larger this value, the higher the responsiveness.
Speed Loop Integration Time Constant*	Sets the speed loop integration time constant. The smaller this value, the higher the responsiveness.
Speed Feed-Forward Ratio*	Sets the speed feed-forward ratio. The larger this value, the higher the responsiveness.
S-ON Signal Logic	Switches the S-ON input logic.
BRAKE Signal Logic	Switches the BRAKE input logic.
Output Signal Selection 1	Selects the output signal.
Output Signal Selection 2	Selects the output signal.
Zero Speed Output Range	Sets the ZV output conditions.
Speed Attainment Output Range	Sets the VA output conditions.
MOVE Signal Min. ON Time	Sets the min. duration that MOVE output is ON.
Alarm Code Output	Enables/disables alarm code output.
Analog Speed Command Gain	Sets the speed command for 1 V of analog input voltage.
Analog Speed Command Clamp	Sets the speed at which the analog speed command is clamped to zero.
Analog Speed Command Offset Voltage	Sets the offset voltage for analog speed command input.
Analog Torque Limit Gain	Sets the torque limiting for 1 V of analog input voltage.
Analog Torque Limiting Offset Voltage	Sets the offset voltage for analog torque limiting input.
Analog Input Signal Automatic Offset	Enables/disables analog input signal automatic offset.
Analog Speed Monitor Max. Value	Sets the max. value for the analog speed monitor. The slope for the analog speed monitor output is decided.
Analog Speed Monitor Max. Voltage	Sets the monitor output voltage for the max. value of the analog speed monitor.
Analog Speed Monitor Offset Voltage	Sets the offset voltage for the analog speed monitor.
Analog Torque Monitor Max. Value	Sets the max. value for the analog torque monitor. The slope for the analog torque monitor output is decided.
Analog Torque Monitor Max. Voltage	Sets the monitor output voltage for the max. value of the analog torque monitor.
Analog Torque Monitor Offset Voltage	Sets the offset voltage for analog torque monitor.
Mechanical Rigidity Setting Switch	Enables/disables the driver's mechanical rigidity setting switch (SW2).
Overvoltage Warning	Sets the voltage at which an overvoltage warning is issued.
Undervoltage Warning	Sets the voltage at which an undervoltage warning is issued.
Overheat Warning	Sets the temperature at which an overheat warning is issued.
Overload Warning	Sets the condition for which an overload warning is issued.
Overspeed Warning	Sets the speed at which an overspeed warning is issued.
Gear Ratio for Speed Monitor	Sets the geared motor gear ratio for speed monitor.

\*When the parameter for selecting operation when the speed control mode is stopped is set to "servo lock".

## ● Torque Control Mode

### ◇ Operating Data

Item	Content
Torque Command	Sets the torque command value. 100% is the rated torque.
Speed Limit	Sets the speed limiting value.

### ◇ System Parameters

Item	Content
Encoder Output Electronic Gear A	Sets the electronic gear denominator for encoder output.
Encoder Output Electronic Gear B	Sets the electronic gear numerator for encoder output.
Analog Input Signal	Enables/disables analog input signals.
Motor Rotation Direction	Sets the torque direction.
Control Module Initial Display	Selects the initial display for when communications start between the control module and the driver. If an item is selected that is not displayed in torque control mode, the monitor mode top screen becomes the initial display.

### ◇ Application Parameters

Item	Content
Output Signal Selection 1	Selects the output signal.
Output Signal Selection 2	Selects the output signal.
Zero Speed Output Range	Sets the ZV output conditions.
MOVE Signal Min. ON Time	Sets the min. duration that MOVE output is ON.
Alarm Code Output	Enables/disables alarm code output.
Analog Speed Limiting Gain	Sets the speed limit for 1 V of analog input voltage.
Analog Speed Limit Clamp	Sets the speed at which the analog speed limit is clamped to zero.
Analog Speed Limit Offset Voltage	Sets the offset voltage for analog speed limit input.
Analog Torque Command Gain	Sets the torque command for 1 V of analog input voltage.
Analog Torque Command Offset Voltage	Sets the offset voltage for analog torque command input.
Analog Input Signal Automatic Offset	Enables/disables analog input signal automatic offset.
Analog Speed Monitor Max. Value	Sets the max. value for the analog speed monitor. The slope for the analog speed monitor output is decided.
Analog Speed Monitor Max. Voltage	Sets the monitor output voltage for the max. value of the analog speed monitor.
Analog Speed Monitor Offset Voltage	Sets the offset voltage for the analog speed monitor.
Analog Torque Monitor Max. Value	Sets the max. value for the analog torque monitor. The slope for the analog torque monitor output is decided.
Analog Torque Monitor Max. Voltage	Sets the monitor output voltage for the max. value of the analog torque monitor.
Analog Torque Monitor Offset Voltage	Sets the offset voltage for analog torque monitor.
Overvoltage Warning	Sets the voltage at which an overvoltage warning is issued.
Undervoltage Warning	Sets the voltage at which an undervoltage warning is issued.
Overheat Warning	Sets the temperature at which an overheat warning is issued.
Overload Warning	Sets the condition for which an overload warning is issued.
Overspeed Warning	Sets the speed at which an overspeed warning is issued.
Gear Ratio for Speed Monitor	Sets the geared motor gear ratio for speed monitor.

## ● Tension Control Mode

### ◇ Operating Data

Item	Content
Tension Command	Sets the tension command. 100% is the rated torque.
Material Thickness*1*2	Sets the material thickness.
Initial Diameter*1*2	Sets the initial diameter for winding or winding out.
Final Diameter*1*2	Sets the final diameter for winding or winding out.
Taper Setting*1*2	This function prevents winding drawing. As the winding diameter increases, the tension is adjusted lower. When it is 100%, the tension becomes constant.
Core Inertia*2	Sets the core inertial moment.
Material Inertia*2	Sets the material inertial moment for the max. material diameter.
Speed Limit	Sets the speed limiting value.

\*1 Set in high function mode I.

\*2 Set in high function mode II.

### ◇ System Parameters

Item	Content
Encoder Output Electronic Gear A	Sets the electronic gear denominator for encoder output.
Encoder Output Electronic Gear B	Sets the electronic gear numerator for encoder output.
Tension Control Mode Selection	Sets the operating mode.
Tension Control Gear Ratio	Sets the gear ratio from the motor shaft to the winding shaft.
Analog Input Signal	Enables/disables analog input signals.
Motor Rotation Direction	Sets the torque direction.
Control Module Initial Display	Selects the initial display for when communications start between the control module and the driver. If an item is selected that is not displayed in tension control mode, the monitor mode top screen becomes the initial display.

### ◇ Application Parameters

Item	Content
Output Signal Selection 1	Selects the output signal.
Output Signal Selection 2	Selects the output signal.
Zero Speed Output Range	Sets the ZV output conditions.
MOVE Signal Min. ON Time	Sets the min. duration that MOVE output is ON.
Alarm Code Output	Enables/disables output.
Analog Speed Limiting Gain	Sets the speed limit for 1 V of analog input voltage.
Analog Speed Limit Clamp	Sets the speed at which the analog speed limit is clamped to zero.
Analog Speed Limit Offset Voltage	Sets the offset voltage for analog speed limit input.
Analog Tension Command Gain	Sets the tension command for 1 V of analog input voltage.
Analog Tension Command Offset Voltage	Sets the offset voltage for analog tension command input.
Analog Input Signal Automatic Offset	Enables/disables analog input signal automatic offset.
Analog Speed Monitor Max. Value	Sets the max. value for the analog speed monitor. The slope for the analog speed monitor output is decided.
Analog Speed Monitor Max. Voltage	Sets the monitor output voltage for the max. value of the analog speed monitor.
Analog Speed Monitor Offset Voltage	Sets the offset voltage for the analog speed monitor.
Analog Torque Monitor Max. Value	Sets the max. value for the analog torque monitor. The slope for the analog torque monitor output is decided.
Analog Torque Monitor Max. Voltage	Sets the monitor output voltage for the max. value of the analog torque monitor.
Analog Torque Monitor Offset Voltage	Sets the offset voltage for analog torque monitor.
Acceleration/Deceleration Correction Filter*2	Sets the acceleration/deceleration correction filter time constant. If the winding operation vibrates during acceleration/deceleration, set this value larger.
Friction Torque Correction*1*2	Sets the friction torque correction. Corrects the torque load for the friction in the mechanism. The value of the torque detected during idling.
Overvoltage Warning	Sets the voltage at which an overvoltage warning is issued.
Undervoltage Warning	Sets the voltage at which an undervoltage warning is issued.
Overheat Warning	Sets the temperature at which an overheat warning is issued.
Overload Warning	Sets the condition for which an overload warning is issued.
Overspeed Warning	Sets the speed at which an overspeed warning is issued.
Gear Ratio for Speed Monitor	Sets the geared motor gear ratio for speed monitor.

\*1 Set in high function mode I.

\*2 Set in high function mode II.

# How to Read Specifications Tables

Product Name	Standard	NX45A-□◇	NX810A-J5-□◇
① Rated Output Power	Electromagnetic Brake Type	NX45M-□◇	NX810M-J5-□◇
①	W	50	100
② Rated Speed	r/min	3000	—
③ Maximum Speed	r/min	5500	—
④ Motor Permissible Speed	r/min	—	3000
⑤ Rated Torque	N·m	0.159	—
⑥ Maximum Instantaneous Torque	N·m	0.478	—
⑦ Permissible Torque	N·m	—	1.27
⑧ Maximum Torque	N·m	—	3.82
⑨ Permissible Speed Range	r/min	—	0 to 600
⑩ Rotor Inertia	J: kg·m <sup>2</sup>	0.0174×10 <sup>-4</sup> [0.0217×10 <sup>-4</sup> ]	0.095×10 <sup>-4</sup> [0.118×10 <sup>-4</sup> ]
⑪ Gearhead Internal Inertia	J: kg·m <sup>2</sup>	—	0.481×10 <sup>-4</sup>
⑫ Permissible Load Inertia	J: kg·m <sup>2</sup>	1.74×10 <sup>-4</sup>	0.012
⑬ Gear Ratio		—	5
⑭ Resolution	P/R	100 to 100000 (Factory setting 1000)	3
Detector		Absolute Encoder	3
⑮ Backlash	arc minutes (degrees)	1 rotation 20 bits, multiple rotations 16 bits	3
Power-Supply Input	Voltage and Frequency	AC Main Power Supply	Single-Phase 100-115 VAC -15%~+10% 50/60 Hz Single-Phase 200-230 VAC -15%~+10% 50/60 Hz Three-Phase 200-230 VAC -15%~+10% 50/60 Hz
	DC Control Power Supply	24 VDC±10% 0.8 A	
⑯ Rated Input Current A	Single-Phase 100-115 VAC	1.9	2.8
	Single-Phase 200-230 VAC	1.2	1.8
	Three-Phase 200-230 VAC	0.7	1.0
Electromagnetic Brake	Type	Power Off Activated Type	
	Power-Supply Input	24 VDC±10%	
	Power Consumption W	6.1	7.2
	Excitation Current A	0.25	0.3
⑰ Static Friction Torque	N·m	0.159	1.27

## ① Rated Output Power

The range in which the temperature rise does not exceed the permissible value when operating continuously at the motor's rated speed and rated torque.

## ② Rated Speed

The speed when the motor is operating at the rated output power.

## ③ Maximum Speed

The max. speed at which the motor can rotate.

## ④ Motor Permissible Speed

The max. speed at which the geared type motor can rotate.

## ⑤ Rated Torque

The torque output when the motor is operating at the rated output power and rated speed.

## ⑥ Maximum Instantaneous Torque

The maximum torque that can be used instantaneously (for a short period of time).

During acceleration and deceleration, the motor can be used up to a max. of this torque.

## ⑦ Permissible Torque

The permissible torque represents the max. value limited by the mechanical strength of the output gear shaft when operated at a constant speed.

## ⑧ Maximum Torque

This is the max. torque value that can be applied to the output gear shaft during acceleration/deceleration such as when an inertial load is started and stopped.

## ⑨ Permissible Speed Range

This is the range for rotation on the output gear shaft.

## ⑩ Rotor Inertia

This refers to the inertia of the rotor inside the motor.

This is necessary when the required torque (acceleration torque) for the motor is calculated.

## ⑪ Gearhead Internal Inertia

The inertia inside the gearhead.

This is necessary when the required torque (acceleration torque) for the motor is calculated.

## ⑫ Permissible Load Inertia

The load inertia at which the motor is stable and can be controlled.

If a load exceeding this value is applied, control becomes unstable, and speed regulation variance, protective circuit activation, vibration, and other problems occur.

## ⑬ Gear Ratio

This is the ratio in rotation speed between the input speed from the motor and the speed of the output gear shaft. For example, a gear ratio of 10 indicates that when the input speed from the motor is 10 r/min, the output gear shaft speed is 1 r/min.

## ⑭ Resolution

This shows the angle that the motor rotates for 1 pulse.

The motor positioning accuracy is determined by the resolution.

## ⑮ Backlash

This is the play of the output gear shaft when the motor shaft is fixed. When positioning in bi-direction, the positioning accuracy is affected.

## ⑯ Rated Input Current

This is the input current value for the main power supply required when the motor is used in the continuous duty region.

## ⑰ Static Friction Torque

This is an electromagnetic brake specification. This is the max. holding torque (holding force) at which the electromagnetic brake can hold the position.

# How to Read Speed – Torque Characteristics

NX620AA-□

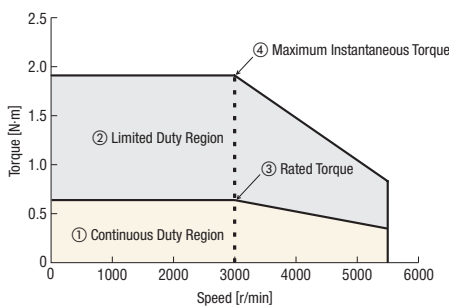

## ① Continuous Duty Region

This refers to the region where a motor can be operated at the continuous ratings. The effective load torque must always be kept in this region.

## ② Limited Duty Region

This region is used when accelerating/decelerating.

## ③ Rated Torque

The torque output when the motor is operating at the rated output power and rated speed.

NX810AA-J5-□

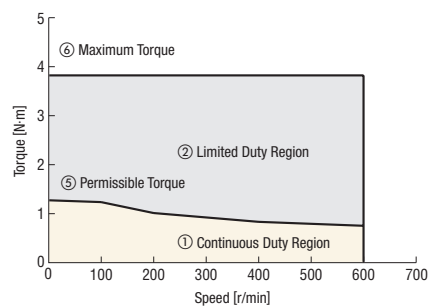

## ④ Maximum Instantaneous Torque

The maximum torque that can be used instantaneously (for a short period of time). During acceleration and deceleration, the motor can be used up to a max. of this torque.

## ⑤ Permissible Torque

The permissible torque represents the max. value limited by the mechanical strength of the output gear shaft when operated at a constant speed.

## ⑥ Maximum Torque

This is the max. torque value that can be applied to the output gear shaft during acceleration/deceleration such as when an inertial load is started and stopped.



# Accessories (Sold separately)

## 1 Connection Cable Sets (RoHS) Flexible Connection Cable Sets (RoHS)

## 2 Extension Cable Sets (RoHS) Flexible Extension Cable Sets (RoHS)

The **NX** Series comes with cables of 1 m, 2 m or 3 m for the connection between the motor and driver. When the distance between the motor and driver is extended to 3 m or longer, a connection cable set or extension cable set must be used.

Use a flexible extension cable if the cable will be bent repeatedly.

### Cable System Configuration

#### When Connecting the Motor and Driver without Using the Included Cables

Use a connection cable set.

Use a flexible connection cable set if the cables will be bent.

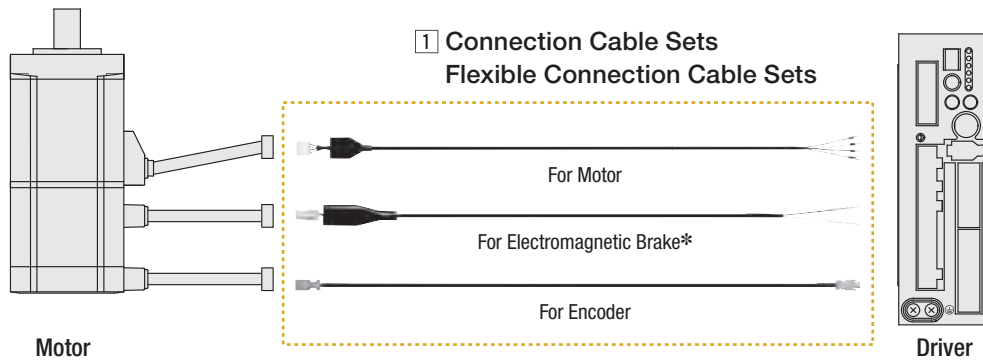

#### When Extending the Distance between the Motor and the Driver Using Included Cables

Use an extension cable set and connect it to the included cables.

Use a flexible extension cable set added if the cables will be bent.

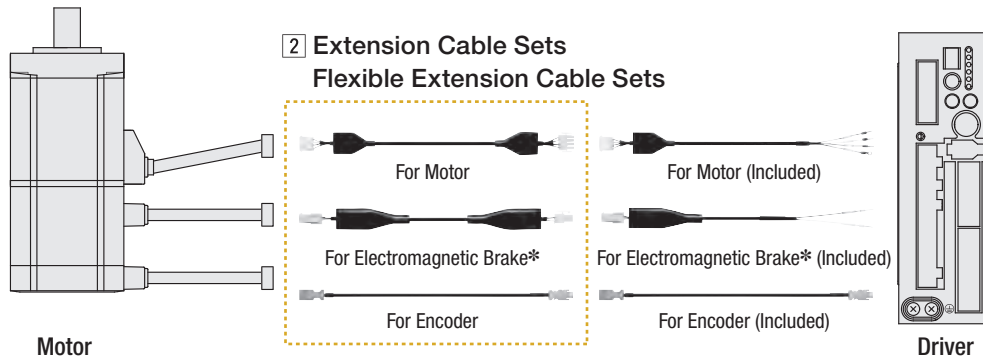

\*Cables for electromagnetic brake are for use when using electromagnetic brake type motors.

#### Note

Keep the overall cable length 20 m max. when using an extension cable set or a flexible extension cable set to connect with cables included with the **NX** Series.

### Note on Use of Flexible Cables

① Do not allow the cable to bend at the cable connector.

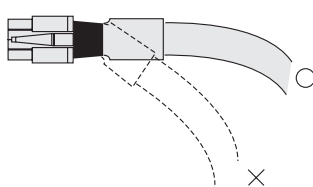

② For the bending radius, use at 6 times min. of the cable diameter.

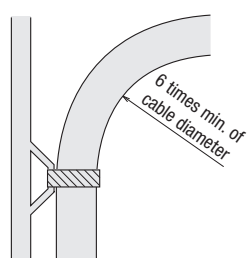

③ The cable from the motor and the included cable are not for bending. If the motor cable is to be bent, bend it at the flexible cable.

#### Flexible Connection Cable

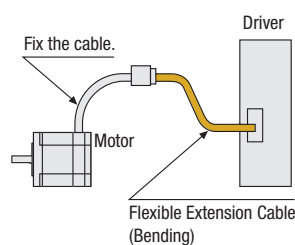

#### Flexible Extension Cable

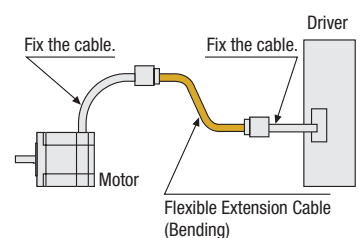



# 1 Connection Cable Sets RoHS

## Flexible Connection Cable Sets RoHS

### Product Line

#### ● Connection Cable Sets

##### ◇ For Standard Type Motor

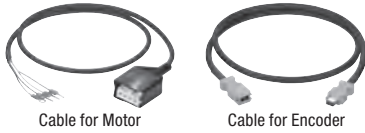

Product Name	Length L (m)
<b>CC050VNF</b>	5
<b>CC070VNF</b>	7
<b>CC100VNF</b>	10
<b>CC150VNF</b>	15
<b>CC200VNF</b>	20

#### ● Flexible Connection Cable Sets

##### ◇ For Standard Type Motor

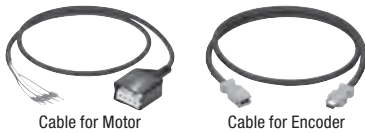

Product Name	Length L (m)
<b>CC010VNR</b>	1
<b>CC020VNR</b>	2
<b>CC030VNR</b>	3
<b>CC050VNR</b>	5
<b>CC070VNR</b>	7
<b>CC100VNR</b>	10
<b>CC150VNR</b>	15
<b>CC200VNR</b>	20

##### ◇ For Electromagnetic Brake Type Motor

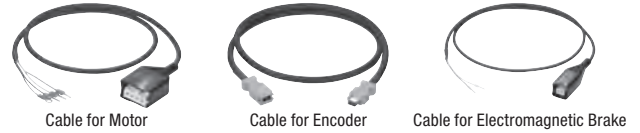

Product Name	Length L (m)
<b>CC050VNF</b>	5
<b>CC070VNF</b>	7
<b>CC100VNF</b>	10
<b>CC150VNF</b>	15
<b>CC200VNF</b>	20

##### ◇ For Electromagnetic Brake Type Motor

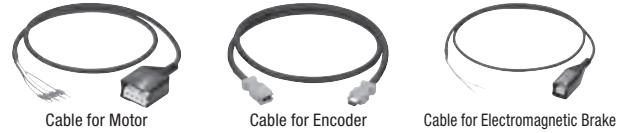

Product Name	Length L (m)
<b>CC010VNR</b>	1
<b>CC020VNR</b>	2
<b>CC030VNR</b>	3
<b>CC050VNR</b>	5
<b>CC070VNR</b>	7
<b>CC100VNR</b>	10
<b>CC150VNR</b>	15
<b>CC200VNR</b>	20

### Dimensions (Unit = mm)

#### ◇ Cable for Motor

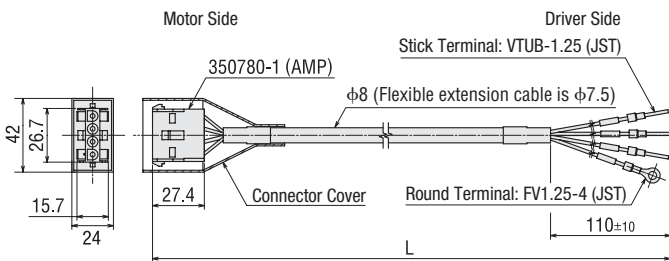

#### ◇ Cable for Encoder

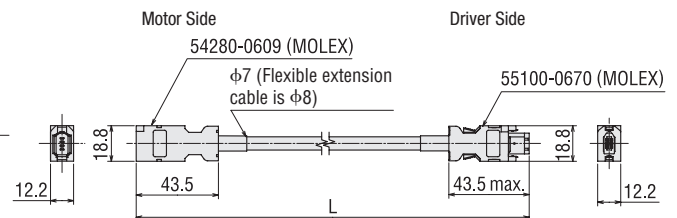

#### ◇ Cable for Electromagnetic Brake

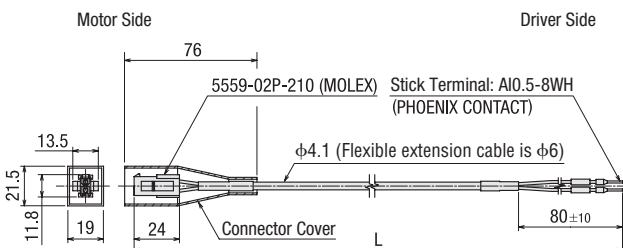

## 2 Extension Cable Sets RoHS

### Flexible Extension Cable Sets RoHS

#### Product Line

##### ● Extension Cable Sets

##### ◇ For Standard Type Motor

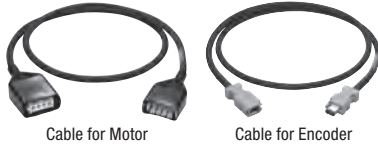

Product Name	Length L (m)
CC010VNFT	1
CC020VNFT	2
CC030VNFT	3
CC050VNFT	5
CC070VNFT	7
CC100VNFT	10
CC150VNFT	15

##### ● Flexible Extension Cable Sets

##### ◇ For Standard Type Motor

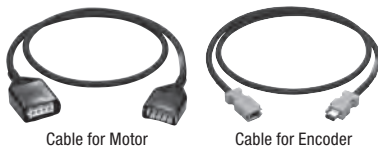

Product Name	Length L (m)
CC010VNRT	1
CC020VNRT	2
CC030VNRT	3
CC050VNRT	5
CC070VNRT	7
CC100VNRT	10
CC150VNRT	15

##### ◇ For Electromagnetic Brake Type Motor

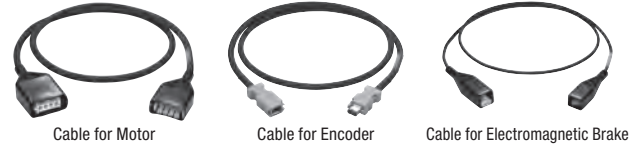

Product Name	Length L (m)
CC010VNFBT	1
CC020VNFBT	2
CC030VNFBT	3
CC050VNFBT	5
CC070VNFBT	7
CC100VNFBT	10
CC150VNFBT	15

##### ◇ For Electromagnetic Brake Type Motor

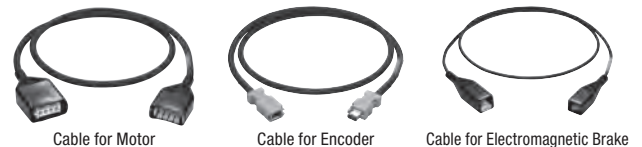

Product Name	Length L (m)
CC010VNRBT	1
CC020VNRBT	2
CC030VNRBT	3
CC050VNRBT	5
CC070VNRBT	7
CC100VNRBT	10
CC150VNRBT	15

#### Dimensions (Unit = mm)

##### ◇ Cable for Motor

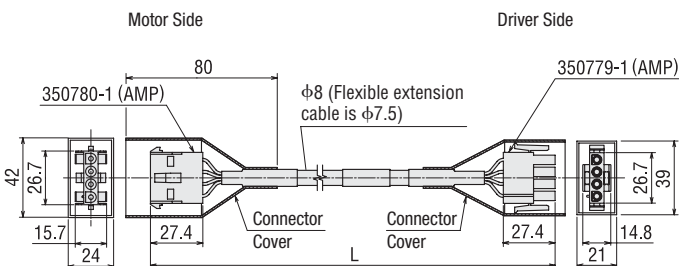

##### ◇ Cable for Encoder

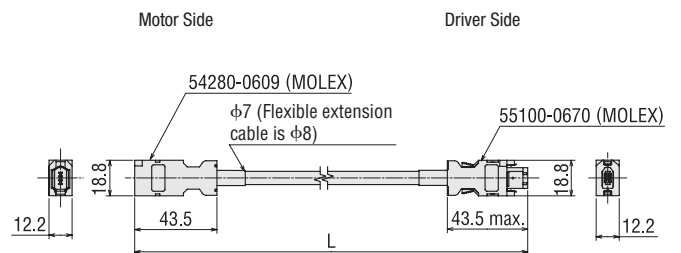

##### ◇ Cable for Electromagnetic Brake

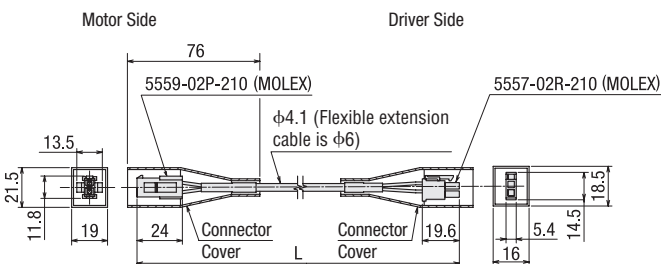

# Driver Cables

## General-Purpose Cables **(RoHS)**



These shielded cables have a half-pitch connector at one end of the cable for easy connecting to the driver.

**Note**

- Note that as the length of the pulse line between the driver and controller increases, the maximum frequency decreases.
- Install a connector that matches the controller you are using to the other end of the cable.

### Product Line

Product Name	Applicable	Length L (m)
CC36D1-1	For CN7 (36 pins)	1
CC36D2-1		2
CC20D1-1	For CN6 (20 pins)	1
CC20D2-1		2

### Dimensions (Unit = mm)

#### CC36D1-1, CC36D2-1

Conductor: AWG28 (0.08 mm<sup>2</sup>)

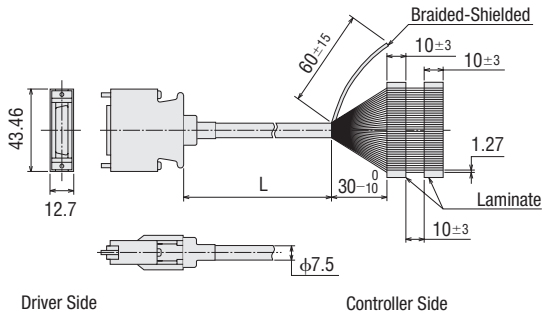

#### CC20D1-1, CC20D2-1

Conductor: AWG28 (0.08 mm<sup>2</sup>)

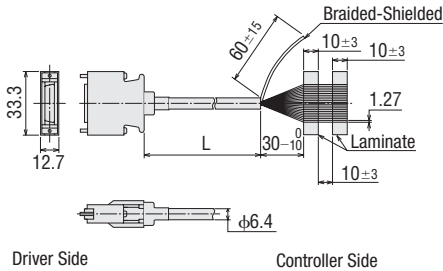

## Connector – Terminal Block Conversion Units **(RoHS)**

These are conversion units that connect a driver to a programmable controller using a terminal block.

- Include a signal name plate for easy, one-glance identification of driver signal names
- DIN rail installable
- Cable length: 1 m



CC36T1



CC20T1

### Product Line

Product Name	Applicable	Length L (m)
CC36T1	For CN7 (36 pins)	1
CC20T1	For CN6 (20 pins)	

### Dimensions (Unit = mm)

#### CC36T1

**CAD** B438

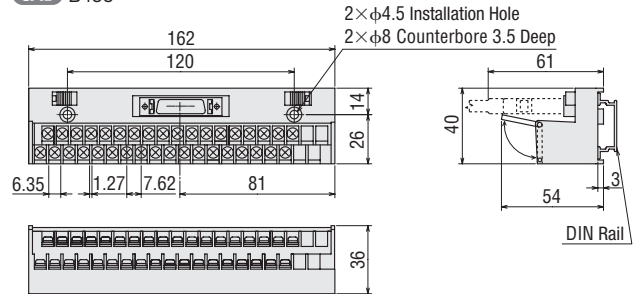

Terminal Block Pin No.

19	20	21	22	23	24	25	26	27	28	29	30	31	32	33	34	35	36
1	2	3	4	5	6	7	8	9	10	11	12	13	14	15	16	17	18

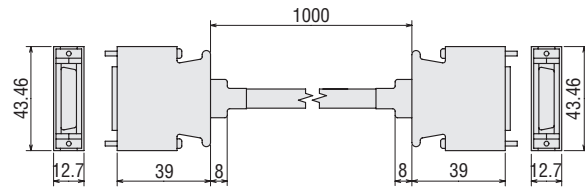

#### CC20T1

**CAD** B437

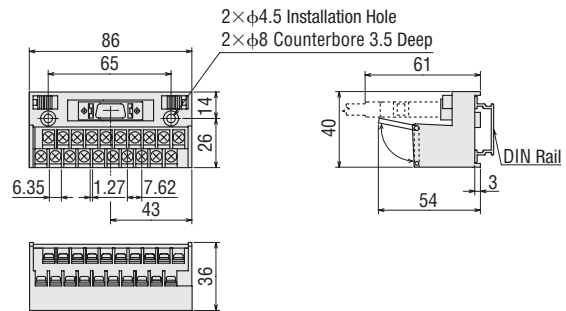

Terminal Block Pin No.

11	12	13	14	15	16	17	18	19	20
1	2	3	4	5	6	7	8	9	10

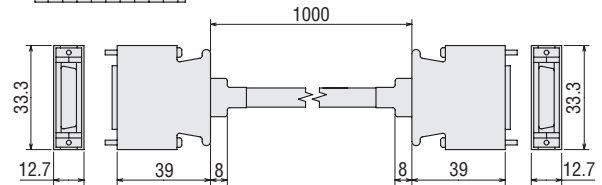

- Applicable Crimp Terminal
- Terminal screw size: M3
- Tightening torque: 1.2 N·m
- Applicable min. lead wire: AWG22 (0.3 mm<sup>2</sup>)

**Note**

- Round terminals cannot be used.

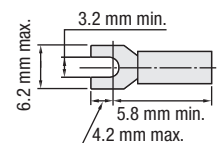

# Control Module RoHS

Allows you to use the **NX** Series extended functions. Makes it possible for you to change parameters, add functions, etc.

## Product Line

Product Name
<b>OPX-2A</b>



## Dimensions (Unit = mm)

### Control Module

Mass: 0.25 kg

CAD B453

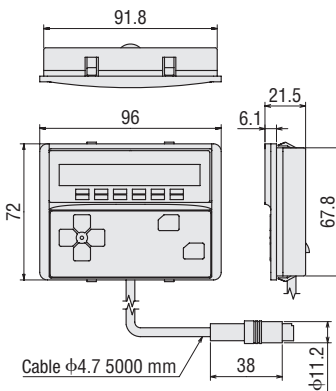

### Panel Cut-Out for Control Module

(Installation plate thickness 1 to 3 mm)

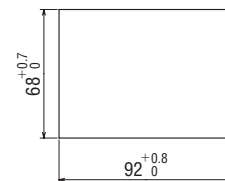

# Data Setting Software RoHS

Allows you to use the **NX** Series extended functions. Allows you to change parameters, add functions, use waveform monitoring to confirm the operation etc. with a computer.

## Product Line

Product Name
<b>MEXE02</b>

(5 m PC interface cable, 0.5 m USB cable included)



## Operating Environment

Operation System	For the operating system, only 32-bit (x86) editions can be used. Windows 2000 Professional Service Pack 4 or later*1 Windows XP Home Edition Service Pack 2 or later Windows XP Professional Service Pack 2 or later Windows Vista Home Basic Service Pack 1 or later Windows Vista Home Premium Service Pack 1 or later Windows Vista Business Service Pack 1 or later Windows Vista Ultimate Service Pack 1 or later
CPU	Pentium III 800 MHz min.*2 (must be compatible with OS)
Memory*2	Windows 2000 Professional : 448 MB min. is recommended Windows XP Home Edition, Professional : 512 MB min. is recommended Windows Vista Home Basic : 896 MB min. is recommended Windows Vista Home Premium : 1.4 GB min. is recommended Windows Vista Business : 1.4 GB min. is recommended Windows Vista Ultimate : 1.4 GB min. is recommended
Hard Disk	Free disk space of 30 MB min.*3*4
Disk Device	CD-ROM Drive
Serial Interface	USB 1.1 1 port

\*1 Application of Rollup 1 is required.

\*2 The operating conditions of the OS must be satisfied.

\*3 The capacity can be increased according to the operating environment.

\*4 Using **MEXE02** requires Microsoft .NET Framework 2.0 Service Pack 1. If it is not installed, it will be installed automatically. An additional max. of 500 MB of free space may be required.

● Windows and Windows Vista are registered trademarks of the Microsoft Corporation in the United States and other countries. Pentium is a registered trademark of Intel Corporation.

## Connection between Computer and Driver

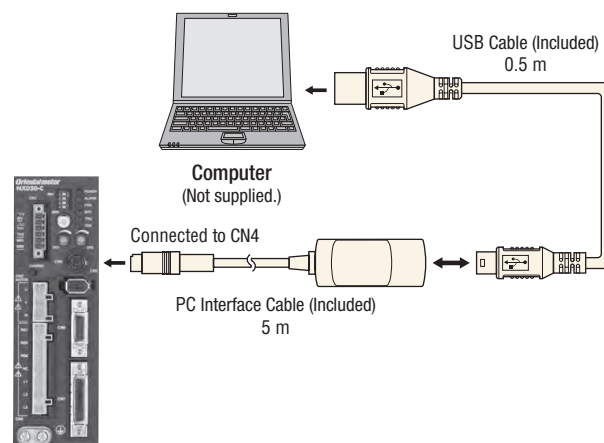

# Flexible Couplings

## MCV Couplings (RoHS)

A flexible coupling ideal for your servo motor is available. Once you have decided on a servo motor type and/or motor applications, you can easily select a coupling of the recommended size.

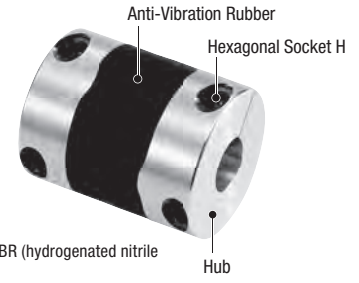

- Materials  
Hub: Aluminum alloy  
Anti-vibration rubber: HNBR (hydrogenated nitrile rubber)

### Features

- Absorbs vibration
- High response
- Zero backlash
- Same characteristics for CW and CCW rotations
- RoHS Directive-compliant

### Product Line

Product Name	Applicable Product
MCV19□□	NX45
MCV25□□	NX410
MCV30□□	NX620
MCV34□□	NX640
MCV39□□	NX975

● A number indicating the coupling inner diameter is entered where the box □ is located within the product name.

### Product Number Code

# MCV 30 08 14

- ①      ②      ③      ④

①	MCV Coupling
②	Outer Diameter Dimension of Coupling <b>19:</b> φ19 mm to <b>39:</b> φ39 mm
③	Inner Diameter d1 (Smaller inner diameter) <b>03:</b> φ3 mm to <b>16:</b> φ16 mm
④	Inner Diameter d2 (Larger inner diameter) <b>04:</b> φ4 mm to <b>16:</b> φ16 mm

### Specifications

Product Name	Normal Torque N·m	Maximum Torque N·m	Maximum Number of Rotations r/min	Inertia kg·m <sup>2</sup>	Static Torsion Spring Constant N·m/rad	Permissible Eccentricity mm	Permissible Declination deg.	Permissible End Play mm	Mass g
MCV19	2.1	4.2	33000	$8.4 \times 10^{-7}$	88	0.15	1.5	±0.2	14
MCV25	4.0	8.0	25000	$30 \times 10^{-7}$	170	0.15		±0.2	28
MCV30	6.3	12.6	21000	$69 \times 10^{-7}$	220	0.20		±0.3	45
MCV34	8.0	16.0	18000	$130 \times 10^{-7}$	390	0.20		±0.3	65
MCV39	13.5	27.0	16000	$270 \times 10^{-7}$	520	0.20		±0.3	98

- If the operating ambient temperature exceeds 30°C, correct the normal torque and the maximum torque with the temperature correction coefficient shown in the table.
- The inertia is the value with the max. shaft hole diameter.

Operating Ambient Temperature (°C)	-20~+30	+30~+40	+40~+50
Temperature Correction Coefficient	1.00	0.80	0.70

### Dimensions (Unit = mm)

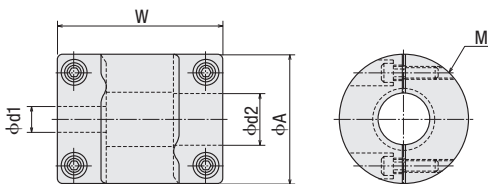

### Shaft Hole Lineup

Product Name	Shaft Diameter d1 mm	Shaft Diameter d2 [mm] (Dimensional tolerance H8)					
		4	5	6	8	10	12
MCV19	5		●	●	●		
	6			●	●		
	8				●		
MCV25	5			●	●		
	6				●	●	
	6.35				●	●	
	8				●	●	●
	10					●	●

Product Name	Shaft Diameter d1 mm	Shaft Diameter d2 [mm] (Dimensional tolerance H8)					
		8	10	12	14	15	16
MCV30	8	●	●	●	●	●	
	10		●	●	●	●	
	12				●		
	14				●	●	
MCV34	8				●		
	10				●		
	12				●		
	14				●	●	●
MCV39	10				●		●
	12				●		●
	14				●	●	●
	15						●
	16						●

● The recommended dimensional tolerance of the applied shaft hole is h6 or h7.

# Accessory Sets RoHS

When using analog I/O, please purchase an accessory set.



AS-SV2

AS-SD1

## Product Line

Product Name	Applicable
<b>AS-SV2</b>	20-Pin Connector for CN6 × 1 Set, External Potentiometers × 2 Sets (Potentiometer × 2, Scale plate × 2, Insulation sheet × 2, Knob × 2, Shielded cable × 2)
Product Name	Applicable
<b>AS-SD1</b>	20-Pin Connector for CN6 × 1 set

# Battery RoHS

This battery is for constructing an absolute system. Position information can be stored during power blackouts or if the driver's power supply is switched OFF.



With the battery installed on an **NX** Series driver

## Product Line

Product Name
<b>BAT01A</b>

# Regeneration Units RoHS

Sometimes the regenerative power generated by the motor exceeds the driver's regenerative power absorption capacity. In such a case, a regeneration unit is connected to the driver to release the regenerative power.

<Conditions under which a regeneration unit may be required>

- When using for vertical operation
- During acceleration and deceleration time when an inertial load is installed

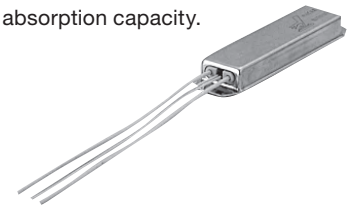

## Product Line

Product Name	Applicable Driver Product Names
<b>RGB100</b>	NXD20-A, NXD20-C
<b>RGB200</b>	NXD75-S

## Specifications

Product Name	RGB100	RGB200
Continuous Regenerative Power	100 W*1	200 W
Resistance Value	150 Ω	50 Ω
Thermal Protector Operating Temperature	Open: 150±7°C Reset: 145±12°C (Normally closed)	Open: 175±5°C Reset: 115±15°C (Normally closed)
Thermal Protector Rated Electricity	120 VAC 4 A 30 VDC 4 A (Min. current 5 mA)	227 VAC 8 A 115 VAC 22 A

\*1 For **NX** Series, 50 W.

- Install the regeneration unit in a location that has the same heat radiation capability as the heat sink (Material: aluminum, 350×350 mm, 3 mm thick).

## Dimensions (Unit = mm)

● For NXD20-A, NXD20-C

Mass: 0.25 kg

CAD C194

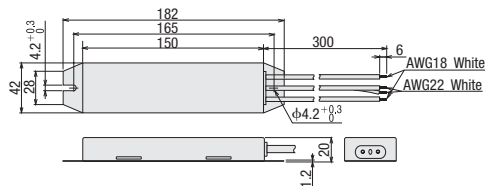

● For NXD75-S

Mass: 1.1 kg

CAD C225

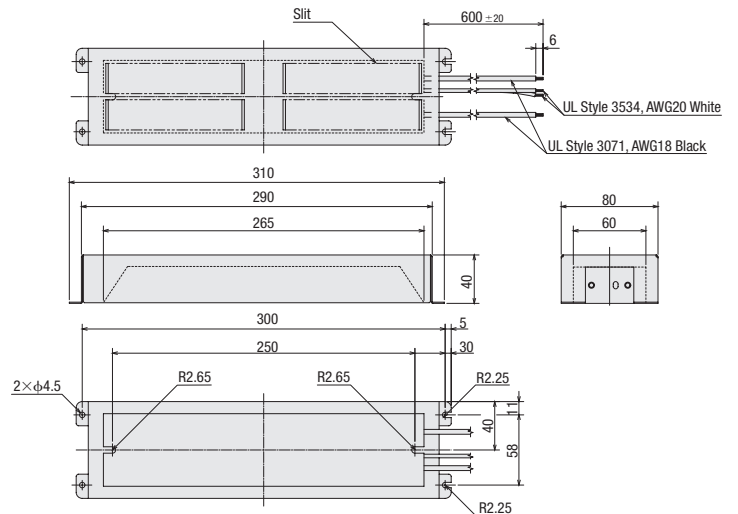

# Controller (Sold separately)

## SG8030J RoHS

### Features

All operations including data setting, etc. can easily be performed using the 4 touch pads on the front panel. In addition, the number of signal lines is reduced to a minimum for easy operation and connection.

- Jerk Limiting Control Function for Suppressing Vibration of the Motor
- Sequential Positioning Operation and External Signal Operation Possible
- Maximum Oscillation Frequency 200 kHz
- 1-Pulse Output Signal/2-Pulse Output Signal Mode Selection Possible



DIN Rail Installation Model



Recessed Installation Model

### Product Line

Type	Product name
DIN Rail Installation Model	<b>SG8030J-D</b>
Recessed Installation Model	<b>SG8030J-U</b>

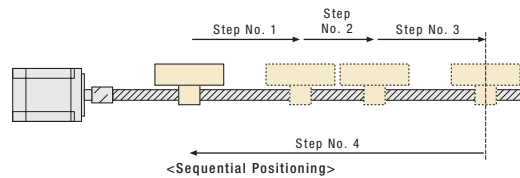

This product is manufactured at a plant certified with the international standards **ISO 9001** (for quality assurance) and **ISO 14001** (for environmental management systems).

Specifications are subject to change without notice.

This catalogue was published in August, 2011.

# Oriental motor

## SINGAPORE ORIENTAL MOTOR PTE LTD

31 Kaki Bukit Road 3, #04-02/04

TECHLINK, Singapore 417818

TEL: +65-6745-7344 FAX: +65-6745-9405

<http://www.orientalmotor.com.sg/>

## ORIENTAL MOTOR (THAILAND) CO., LTD.

900, 8th Floor Zone C, Tonson Tower, Ploenchit Road,

Lumpini, Pathumwan, Bangkok 10330 Thailand

TEL: +66-2-251-1871 FAX: +66-2-251-1872

<http://www.orientalmotor.co.th/>

## ORIENTAL MOTOR (MALAYSIA) SDN. BHD.

### Headquarters & Kuala Lumpur Office

A-13-1, North Point Offices, Mid Valley City,

No.1 Medan Syed Putra Utara 59200

Kuala Lumpur, Malaysia

TEL: +60-3-22875778 FAX: +60-3-22875528

### Penang Office

TEL: +60-4-6423788 FAX: +60-4-6425788

### Johor Bahru Office

TEL: +60-7-3314257 FAX: +60-7-3314259

<http://www.orientalmotor.com.my/>

## Customer Support Centre (Support in English & Chinese)

For Singapore: 1800-842 0280\* \* Free Call Mon-Fri: 09:00-17:30 Singapore Time

For Malaysia: 1800-806 161\*

For Other Countries: +65-6842-0280

Mail to: [support@orientalmotor.com.sg](mailto:support@orientalmotor.com.sg)

## Japanese Customer Support Centre (Asia and Oceania Areas)

+65-6745-3008

Mon-Fri: 09:00-17:30 Singapore Time

Mail to: [j-support@orientalmotor.com.sg](mailto:j-support@orientalmotor.com.sg)

For more information please contact: